



SUMMER INFANT

Affirm 335

Type: Rear-facing-only
Last date made: Current
First made: 2020
Weight limits: 3 to 35 lbs.
Harness: 5-point harness



Harness: Shoulder straps are attached to splitter plate behind seat. Push lever at lower front of seat and pull on shoulder straps to loosen.

Harness slots: There are four sets of slots (diagram 1). To move harness straps, remove from splitter plate, re-thread through desired slots, then re-attach to splitter plate. If harness straps are inserted into Harness Slot Positions 2, 3 or 4, use the end loops (diagram 2). If child is under 8 lbs. and harness is in Harness Slot Position 1, place harness straps on the inner loop with straps in front of splitter plate (diagram 3).

Buckle strap: There are three positions. Use one closest to, but not under, child. To change position, turn carrier over and push buckle retainer through slot. Pull buckle strap through seat and seat pad; then insert in desired slot.

Angle adjustment: Base has four recline positions. Pull up recline adjustment lever while holding front of base. (diagram 4). Extend or retract recline foot until blue square is FULLY visible in level indicator window (diagram 5). If installing restraint without base, level indicator is red line on side of restraint.

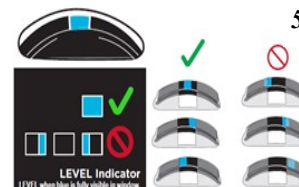
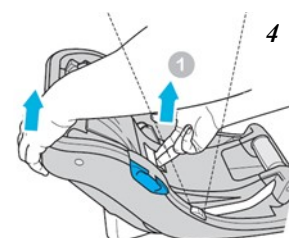
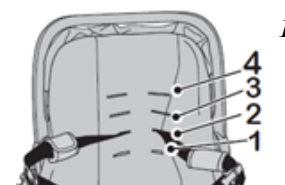

SEE PAGE 2

Belt path: When not in use, place lower connector strap and hooks inside storage (diagram 6).

With base: **Do not install base using inflatable safety belt.**

Rotate handle on base to open belt tensioning arm (diagram 7). Route the lap-only or lap-shoulder belt through BLUE belt guides on both sides of base and buckle. Close belt tensioning arm. Summer Infant strongly recommends locking the vehicle shoulder belt to prevent entanglement, however, belt tensioning arm is a true lock-off. No locking clip is needed if the retractor cannot be locked.

Without base: Route lap belt portion of vehicle belt into belt guides on carrier and buckle. Either lift shoulder belt over handle, around carrier, and slide into the blue shoulder belt guide on rear of seat (diagram 8) or allow shoulder belt to rest against back of vehicle seat. Lock belt. Belt guide is NOT a lock-off, belt must be locked! Contact Summer Infant customer service for a locking clip if belt does not lock.

LATCH: A single lower connector strap is attached to base. Rotate handle on base to open the belt tensioning arm (diagram 7). Remove lower connector strap from storage (diagram 6) and route through blue belt guides on both sides of the base. (diagram 9). Tighten strap enough to take slack out. Close belt tensioning arm. May be installed **borrowing** anchors from the outboard seating positions if distance between inner anchors is between 11 and 20 inches and vehicle owner's manual does not prohibit it. (refer to Safe Ride News LATCH manual).

Handle: There are 4 handle positions (diagram 10), only Positions 1 & 2 may be used in the vehicle, position 1 is recommended. To adjust, push handle adjustment buttons on both sides of seat and then rotate the handle.

Other: Body insert is optional for infant between 3 lbs. and 11 lbs. Body insert is ONLY intended to be used when harness is in the first or second harness slots and the buckle strap is in the inner or middle slots (diagram 11). To install body insert, thread hook and loop straps through the top harness slots and fasten (diagram 12).

If needed, a shorter buckle strap can be requested by contacting Summer Infant Customer Service.

Certified for use on aircraft only when installed **without** the base.

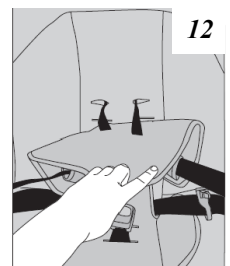
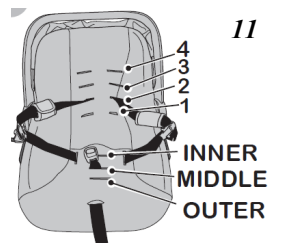
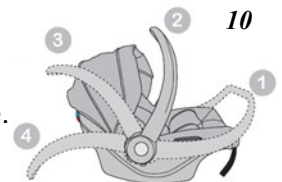
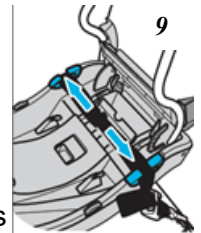
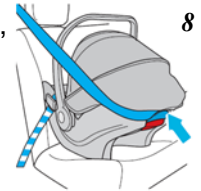
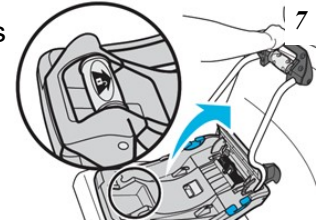



summer™ 

AFFIRM™ 335

REAR-FACING INFANT CAR SEAT

Weight: 3-35 lbs (1.4 - 15.8kg)

Height: 15-32 in. (38 - 81cm)

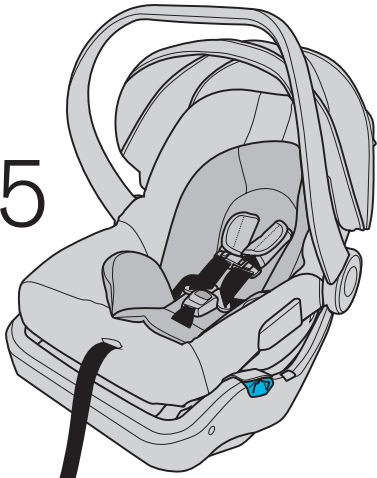

INSTRUCTION MANUAL

Please read the following instructions and warnings carefully
before set up and use.

KEEP THIS INSTRUCTION MANUAL FOR FUTURE REFERENCE.

TABLE OF CONTENTS

REGISTRATION AND RECALL INFORMATION	4-5
CERTIFICATION AND USEFUL LIFE	6
QUESTIONS AND ASSISTANCE	7
WARNINGS AND IMPORTANT SAFETY INFORMATION	8-17
CHILD FIT INFORMATION	18-19
OVERVIEW OF THE AFFIRM™ 335 STEELOCTM BASE.....	20-21
OVERVIEW OF THE AFFIRM™ 335 INFANT CARRIER.....	22-23
UNIQUE FEATURES OF THE AFFIRM™ 335.....	24-25
FEATURES - HANDLE	26
FEATURES - CANOPY	27
FEATURES - INFANT BODY INSERT	28-29
CHECKING CHILD FIT IN THE CARRIER.....	30-33
CHANGING CROTCH BUCKLE LOCATION	34-35
CHANGING HARNESS STRAP LOCATION	36-39
SECURING YOUR CHILD IN THE INFANT CARRIER	40-43
REMOVING YOUR CHILD FROM THE CARRIER	44-45
LATCH USAGE	46-47
VEHICLE SEATING LOCATIONS.....	48
SAFE VEHICLE BELT TYPES THAT CAN BE USED	49
UNSAFE VEHICLE BELT TYPES THAT CANNOT BE USED	50-51

BASE INSTALLATION WITH LATCH / BASE REMOVAL	52-57
BASE INSTALLATION WITH VEHICLE LAP/SHOULDER BELT ...	58-61
BASE INSTALLATION WITH VEHICLE LAP BELT	62-65
CARRIER INSTALLATION WITHOUT THE BASE WITH VEHICLE LAP/SHOULDER BELT AND SHOULDER BELT GUIDE	66-69
CARRIER INSTALLATION WITHOUT THE BASE WITH VEHICLE LAP/SHOULDER BELT	70-73
CARRIER INSTALLATION WITHOUT THE BASE WITH THE LAP BELT	74-75
ADJUSTING THE RECLINE	76
CHECKING THE RECLINE WITH THE BASE	77
ADJUSTING THE RECLINE ANGLE WITHOUT THE BASE	78-79
USING THE INFANT CARRIER ON AN AIRCRAFT	80-83
LATCH STORAGE	84
INSTRUCTION MANUAL STORAGE	84
CARE AND MAINTENANCE.....	85-91
WARRANTY AND REPLACEMENT PARTS.....	92

TABLE OF CONTENTS

REGISTRATION AND RECALL INFORMATION

Registering Your Child Restraint

Child restraints could be recalled for safety reasons. You must register this restraint to be reached in a recall. Send your name, address, e-mail address, if available, and the restraint's model number and manufacturing date to:

Summer Infant (USA), Inc.
1275 Park East Drive
Woonsocket, RI 02895
or call 1-401-671-6551
or register online at:

<http://www.summerinfant.com/carseatregistration>

For Recall Information

Call the U.S. Government's Vehicle Safety Hotline at
1-888-327-4236
(TTY:1-800-424-9153),
or go to *<http://www.NHTSA.gov>*

REGISTRATION AND RECALL INFORMATION

Please complete the pre-paid registration card that is attached to your child restraint and send in the portion shown today.

Tear off and mail this part

Consumer: Just fill in your name and address and e-mail address.		
Your Name _____		
Your Street Address _____		
City _____	State _____	Zip Code _____
E-mail Address (optional) _____		
CHILD RESTRAINT REGISTRATION CARD		

Model Name / Nombre del modelo:		
Model Number / Número del modelo:		
Manufactured in / Fabricado en:		
Year / Año	Month / Mes	Day / Día
DO NOT USE AFTER / NO USAR DESPUÉS DE:		
Summer Infant (USA), Inc. 1275 Park East Drive Woonsocket, RI 02895		
1-401-671-6551	Factory Code / Código de fabrica : 109	
Batch No.	Made in China / Hecho en China	

D0000000351 8/19

For future reference, record the model number of your child restraint AND the date of manufacture below:

MODEL NUMBER: _____

DATE OF MANUFACTURE: _____

CERTIFICATION AND USEFUL LIFE

Certification

This child restraint system conforms to all applicable Federal motor vehicle safety standards (FMVSS 213). It is not intended to be used in boats, shopping carts, low-speed vehicles such as ATV's, golf carts or any other non-certified vehicle.

This Restraint is Certified for Use in Motor Vehicles and Aircraft.

The child restraint's base is NOT certified for use in aircraft.

Contact your airline for specific policies or for more information.

Useful Life NEVER use this child restraint when it is older than six (6) years. The date of manufacture can be found on a label on the underside of the infant carrier or in the center of the base.

Model Name / Nombre del modelo:

Model Number / Número del modelo:

Manufactured in / Fabricado en:

Year / Año	Month / Mes	Day / Día
------------	-------------	-----------

DO NOT USE AFTER / NO USAR DESPUÉS DE:

Summer Infant (USA), Inc. 1275 Park East Drive Woonsocket, RI 02895

1-401-671-6551

Factory Code / Código de fabrica : 109

Batch No.

Made in China / Hecho en China

00000000351 8/19

QUESTIONS AND ASSISTANCE

Questions or Assistance?

If you have any questions regarding installation of your child restraint, before contacting us have your model name and number available, you can find this on a label located on the underside of your carrier or in the center of the base.

Summer Infant (USA), Inc.
1275 Park East Drive,
Woonsocket, RI 02895
1-401-671-6551
www.summerinfant.com

**Date of
Manufacture
Label Locations**

**Center
of Base**

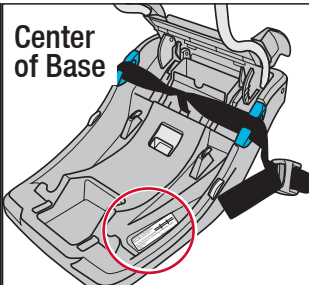

**Underside
of Carrier**

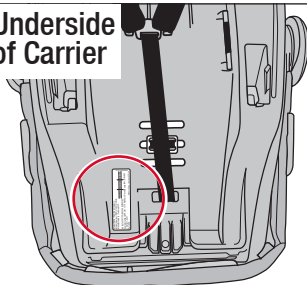

Helpful information about Child Restraints:

www.NHTSA.gov
www.seatcheck.org
www.safekids.org
www.healthychildren.org

WARNINGS AND IMPORTANT SAFETY INFORMATION

AIRBAG WARNINGS:

⚠️ WARNING ⚠️ ADVERTENCIA



DO NOT place rear-facing child seat on front seat with air bag. **DEATH OR SERIOUS INJURY** can occur. The back seat is the safest place for children 12 and under.

NO coloque un asiento de seguridad para bebés orientado hacia atrás en el asiento delantero del automóvil con bolsa de aire. Podría resultar en **MUERTE O LESIONES GRAVES**, el asiento trasero es el lugar más seguro para los niños de 12 años y menores.

D000000260 8/19

WARNINGS AND IMPORTANT SAFETY INFORMATION

⚠️ WARNING! DEATH or SERIOUS INJURY can occur,

AIRBAG WARNINGS:

- **READ THIS MANUAL CAREFULLY!**

- **DO NOT** use this restraint in the vehicle seats equipped with air bags. Interaction between a rear-facing child restraint and air bags may cause death or serious injury. If your vehicle has an air bag, refer to the vehicle owner's manual for child restraint installation.
- Owners of vehicles with front passenger side airbags should refer to their vehicle owner's manual for child restraint installation instructions.
- **DO NOT** place any objects between the restraint and the side air bag, as an air bag expands it may cause the objects to cause injury to your child.
- Refer to your vehicle's Owner's Manual for information about vehicle seat belt systems, air bags, side air bags, front passenger side air bags and child restraint installations, to determine correct seating positions.

!WARNING! DEATH or SERIOUS INJURY can occur,

GENERAL WARNINGS:

- **READ** this Owner's Manual carefully before use and keep it for future reference. Failure to follow these instructions and the warnings on the child restraint can result in death or serious injury of your child in a crash.
- **FOLLOW ALL INSTRUCTIONS** on this child restraint and in the written instructions stored in the base or under the seat pad.

LOOK for the book icon:



- **NEVER** install or use this child restraint until you have read and understand the instructions in this manual, the labels on your child restraint and in your vehicle Owner's Manual. If there is a conflict between them, the vehicle Owner's Manual must be followed.
- **DO NOT ALLOW** others to install or use this child restraint unless they understand how to correctly install and use it.
- **ONLY** place this child restraint **REAR-FACING** in a vehicle seating location allowed by the vehicle manufacturer.

⚠️ WARNING! DEATH or SERIOUS INJURY can occur,

WHEN USED INSIDE A VEHICLE:

- Use only in a rear-facing position when using it in the vehicle.
- Use only with children who weigh between 3 - 35 lbs (1.4kg-15.8kg) and whose height is between 15 and 32 in. (38-81 cm).
- Snugly adjust the belts provided with this child restraint around your child.
- Secure this child restraint with the vehicle's child restraint anchorage system if available or with a vehicle belt.
- Follow all instructions on this child restraint and in the written instructions located under the seat pad or in the base.
- Register your child restraint with the manufacturer.
- Never leave child unattended.
- **ALWAYS** use handle in position **1** or **2** in the vehicle.
- **ALWAYS CHECK THE REAR VEHICLE SEAT TO PREVENT LEAVING A CHILD ALONE IN THE VEHICLE.**
- **ACCORDING TO ACCIDENT STATISTICS**, children are safer when properly restrained in the rear seating positions than in the front seating positions.
- Child's head **MUST** be 1 inch (2.5 cm) or more below the top of the child restraint.
- The infant body insert can be used for infants between 3 (1.4kg) and 11 lbs (5kg).

WARNING! DEATH or SERIOUS INJURY can occur,

WHEN USED INSIDE A VEHICLE (CONT.):

- **SOME CHILDREN WITH SPECIAL NEEDS**, such as premature infants or those who have tested positive for positional apnea, may be at increased risk of suffering breathing or other difficulties in a child restraint. Please consult a physician to determine what type of child restraint should be used.
- **DO NOT** use this or any other child restraint with a premature, low birth weight, or medically fragile infant, UNTIL you have consulted with your doctor and hospital. Some infants may have difficulty breathing or have other medical problems when placed in a seated position.
- **NEVER** install this child restraint in vehicle seats that face the rear or side of the vehicle.
- **ALWAYS** keep your child properly secured in the harness. A snug strap should not allow any slack. It lies in a relatively straight line without sagging. It does not press on the child's flesh or push the child's body into an unnatural position.
- **NEVER** use bulky clothing or blankets that will interfere with properly positioning or tightening the harness. Always buckle harness when child is in the child restraint.
- **NEVER LEAVE CHILD UNATTENDED** in or around the vehicle. Vehicle backovers can happen in any type of vehicle. Vehicles have blind spots, the areas around the vehicle that you can not see from the driving position. Always check around the vehicle before moving your vehicle.

WARNING! DEATH or SERIOUS INJURY can occur,

WHEN USED INSIDE A VEHICLE (CONT.):

- **If using a base, ONLY USE** with the Summer Infant Affirm™335 Steeloc™ base. **ALWAYS** check to make sure the infant carrier is securely attached to the base. After attaching the infant carrier to the base, lift up on the infant carrier handle to make sure that it is securely attached to the base.
- **NEVER** use this child restraint in a vehicle seating position where it cannot be secured tightly. A loosely installed child restraint will not protect your child in a crash.
- **NEVER LEAVE** a vehicle seat back with a folding mechanism unlocked. In the event of a sudden stop, an unlocked vehicle seat back could prevent this child restraint from protecting your child.
- **NEVER** use this child restraint with any motorized, or door mounted vehicle seat belts. Your child restraint would not be properly restrained in the event of a crash.
- **DO NOT USE** this child restraint with inflatable seat belts.
- **BEFORE** each use, **ALWAYS** check that the child restraint is tightly secured in the vehicle seat and does not move more than 1 inch (2.5 cm) in any direction when checked at the belt path.
- **ALWAYS** check buckles and other parts for hot surfaces before placing your child in the child restraint. A hot surface could burn your child! Cover an unoccupied child restraint with a blanket when leaving it in a vehicle exposed to sunlight.

!WARNING! DEATH or SERIOUS INJURY can occur,

WHEN USED INSIDE A VEHICLE (CONT.):

- **NEVER** leave an empty child restraint unsecured in your vehicle. The child restraint systems should be securely belted to the vehicle, even when they are not occupied. Since in a crash an unsecured child restraint system may injure other occupants in a sudden stop or crash.
- **ALWAYS** store the **LATCH** connectors when they are not being used.
- **NEVER** use this child restraint if any of the harness or **LATCH** straps are cut, frayed, or damaged in any way.
- **NEVER** use accessories or parts with this child restraint other than those approved by Summer Infant. Use of accessories or parts from other manufacturers could cause the child restraint not to perform as intended in a vehicle crash.

USING THE INFANT CARRIER OUTSIDE A VEHICLE

- **NEVER** leave child unattended.
- **Suffocation Hazard:** Infant carrier can roll over on soft surfaces and suffocate child. **NEVER** place carrier on beds, sofas, or other soft surfaces.
- **Fall Hazard:** Child's activity can move carrier. **NEVER** place carrier on counter tops, tables, or any other elevated surface.



- **DO NOT** use on shopping carts.

!WARNING! DEATH or SERIOUS INJURY can occur,
USING THE INFANT CARRIER OUTSIDE A VEHICLE (CONT.)

!WARNING ! ADVERTENCIA



Children have **STRANGLED** in loose or partially buckled harness straps. Fully restrain the child even when carrier is used outside the vehicle.

Los niños se han **ESTRANGULADO** con las correas del arnés sueltas o parcialmente abrochadas. Restringir totalmente al niño, incluso cuando el vehículo se utiliza fuera del vehículo.

D000000388 8/19

- **ALWAYS** keep your child properly secured in the harness, even when using the carrier outside of the vehicle.
- **MAKE SURE** the handle is locked in Position 2 before carrying the child restraint. An unlocked handle could move unexpectedly, causing child to fall.
- **DO NOT** place items with a string around child's neck, such as hood strings or pacifier cords. Strings and cords can cause strangulation!
- **DO NOT** place a carrier near a window where blind cords or drapes can strangle a child. **DO NOT** hang strings or attach strings to toys.

⚠️ WARNING! DEATH or SERIOUS INJURY can occur,

ADDITIONAL WARNINGS:

- **ALWAYS** replace the child restraint and base after a crash of any kind even if it was unoccupied. A crash can cause unseen damage to the child restraint that may not be visible.
- **NEVER** use infant carrier or base if it has damaged, broken or missing parts.
- **Overhang of base on vehicle seat:** 20% of the Affirm™335 Steeloc™ base is allowed to hang over edge of the vehicle seat. The Affirm™335 is allowed to touch the vehicle seat(s) in front of it, as long the recline angle of the child restraint is not affected.
- Store the infant carrier and base in a safe dry place when it will not be used for long periods of time. To avoid any damage, DO NOT place heavy objects on top of the carseat and base.
- **DO NOT** allow children to play with this child restraint.
- **DO NOT** attempt to make repairs to or otherwise modify or tamper with this child restraint.
- **AVOID** using the carseat or base unless you know the complete history of the product. **NEVER** allow someone else to use this child restraint and base without also passing along this manual to them.

⚠️ WARNING! DEATH or SERIOUS INJURY can occur,

ADDITIONAL WARNINGS:

- **NEVER** purchase second-hand child restraints as you do not know their history and may be missing components integral to their safety.
- **DO NOT** allow children to play with vehicle seat belts. They may create an entanglement hazard for any child that can reach the seat belt and may wrap it around his or her neck.
- **DO NOT** leave loose objects (e.g. groceries, books, handbags) in a vehicle. In the event of a sudden stop, loose objects will keep moving, potentially causing serious injuries.
- **DO NOT** carry the child restraint by the canopy or harness adjuster strap.
- **NEVER** take your child out of the infant car seat while the vehicle is moving. Unrestrained occupants are at a greatly increased risk of death or serious injury in a car crash.
- **DO NOT** twist base handle while carrying the base.

CHILD FIT INFORMATION

The American Academy of Pediatrics recommends infants and toddlers should ride in a rear-facing car safety seat as long as possible, until they reach the highest weight or height allowed by their seat. Also, some states' laws require children to be rear-facing until age 2. Please review your applicable local or state laws related to child passenger safety before installing and using this child restraint.

Your child **MUST** meet the height and weight requirements:

Weight: 3 - 35 lbs. (1.4 kg - 15.8 kg)

Height: 15 - 32 in. (38 - 81cm)

The infant body insert is optional for child between 3 lbs (1.4kg) and 11 lbs (5kg).

DO NOT use this or any other child restraint with a premature, low birth weight, or medically fragile infant, until you have consulted with your doctor. Some infants may have difficulty breathing or have other medical problems when placed in a seated position.

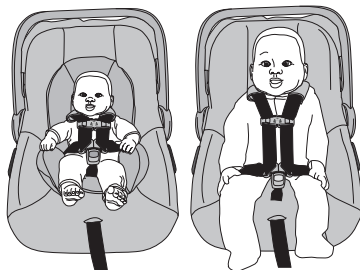

CHILD FIT INFORMATION

CHILD'S HEAD MUST be 1" (2.5 cm) or more below the top of the seat as shown

Minimum 1 inch (2.5 cm)



Hold ruler up at the top of the seat to **CHECK** for correct 1" (2.5 cm) spacing

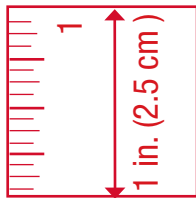

Harness straps must be adjusted to be **AT** or **JUST BELOW** child's shoulders

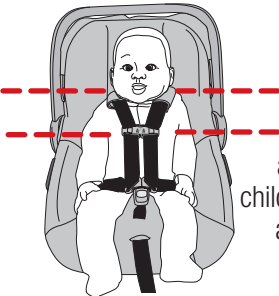

Chest clip at center of child's chest at armpit level

OVERVIEW OF THE AFFIRM™ 335 STEELOC™ BASE

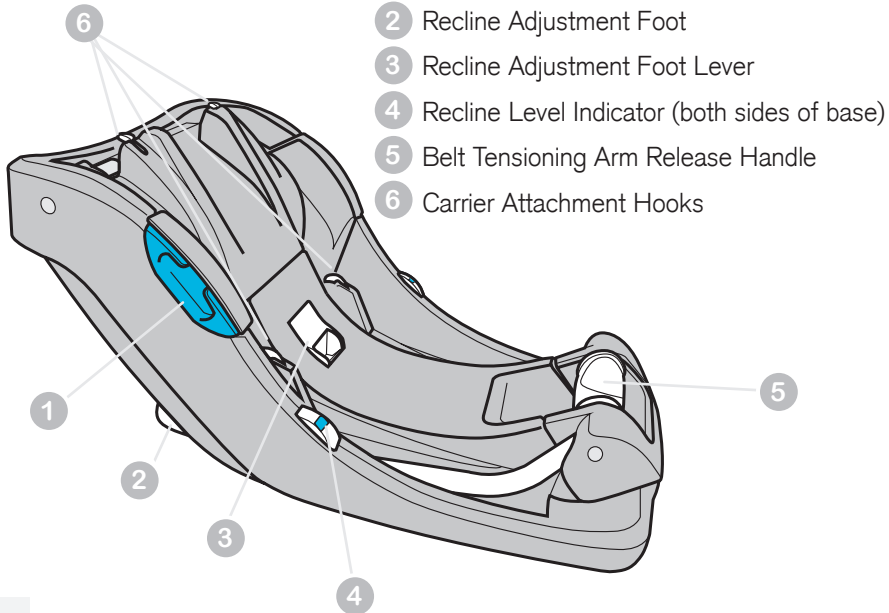

SIDE VIEW

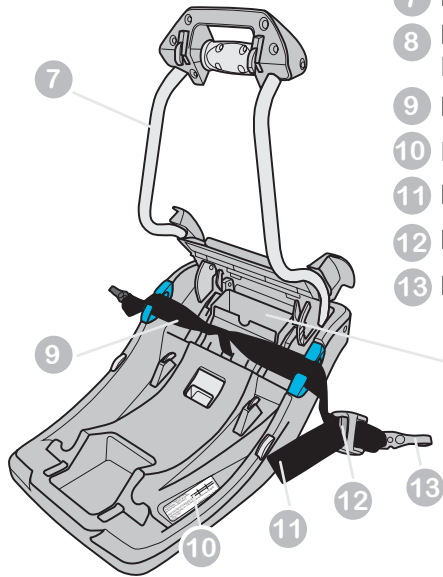

OVERVIEW OF THE AFFIRM™ 335 STEELOC™ BASE

OPEN VIEW



- 7 Belt Tensioning Arm
- 8 **LATCH**  Storage and Instruction Manual Storage
- 9 **LATCH**  belt
- 10 Date of Manufacture Label Location
- 11 **LATCH**  Strap
- 12 **LATCH**  Adjustment Release Button
- 13 **LATCH**  Hook

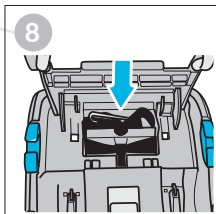

 **LATCH stored**

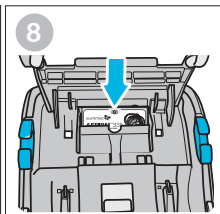

 **Instruction Manual stored**

OVERVIEW OF THE AFFIRM™ 335 INFANT CARRIER

FRONT VIEW

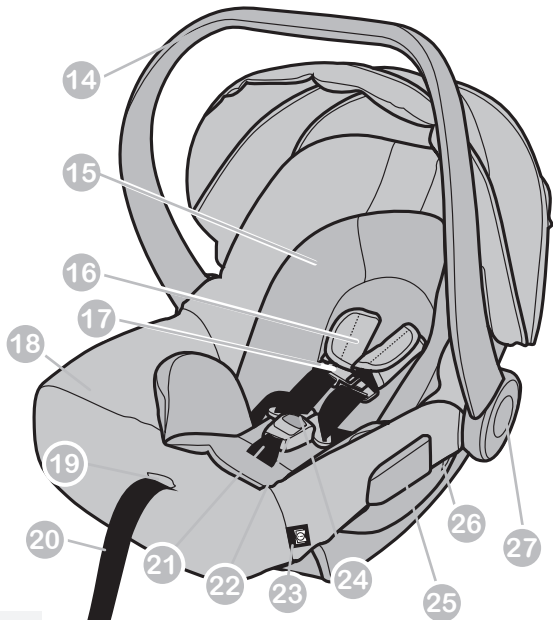

- 14 Anti-Rebound / Carry Handle
- 15 Infant Body Insert
- 16 Harness Covers
- 17 Chest Clip
- 18 Seat Pad
- 19 Harness Adjuster Button (under seat pad)
- 20 Harness Adjuster Strap
- 21 Crotch Strap
- 22 Harness Buckle
- 23 Instruction Manual Storage (pocket under seat pad)
- 24 Harness Release Button
- 25 Vehicle Belt Guide
- 26 Stroller Attachment Door
- 27 Handle Adjustment Button

OVERVIEW OF THE AFFIRM™ 335 INFANT CARRIER

REAR VIEW

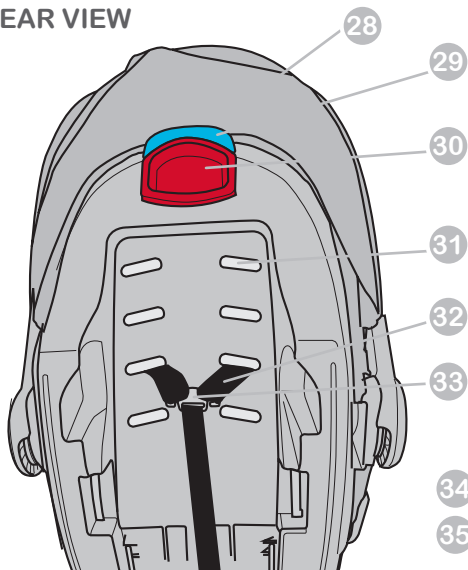

- 28 Canopy
- 29 Shoulder Belt Guide
- 30 Carrier Release Handle
- 31 Harness Slots
- 32 Harness Straps
- 33 Harness Splitter Plate
- 34 Crotch Strap Slots
- 35 Crotch Buckle Retainer
- 36 Date of Manufacture Label Location

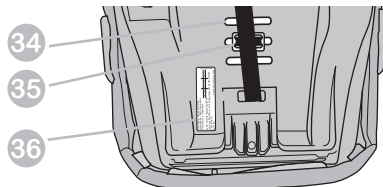

UNIQUE FEATURES OF THE AFFIRM™335



Steeloc™ Base

Steel reinforced base for added security. Easily installs for a secure fit.

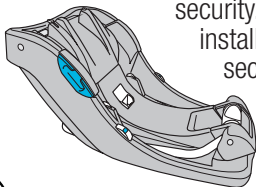

FloatCarry™

Designed to minimize strain. Handle allows parents to comfortably carry the car seat with their arm through the handle and grabbing the knuckle.

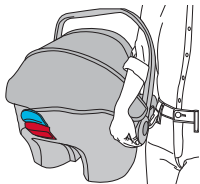

Full-Surround Energy Absorbing Foam

Energy absorbing foam fully surrounds the car seat. This added protection helps absorb crash forces and could minimize injury.



Integrated Anti-Rebound Handle

For added stability, when the handle is in the anti-rebound position, it could lessen the risk of injury to a child in the event of a crash.



UNIQUE FEATURES OF THE AFFIRM™ 335



Front Impact Tested - Meets or exceeds the child restraint criteria for a frontal crash test under US FMVSS 213.

Side Impact Tested - Side impact tested for occupant protection and retention using the proposed FMVSS Side Impact Standard.

Rear-Impact Tested - Based on European rear impact crash test procedures.

Rollover Tested - Based on European roll over crash test procedures.

Aircraft Approved - Certified for use in an aircraft when used without a base.

ASTM 2050 Compliant - Conforms to ASTM 2050 Standard Consumer Safety Specification for Hand-Held Infant Carriers.

2X Impact Force Tested - Tested using approximately twice the impact force required by US FMVSS 213 Car Seat Standard.

FEATURES - HANDLE

! WARNING

TO AVOID SERIOUS INJURY, ALWAYS make sure the handle is securely locked in the upright carrying position **2** before carrying.

THERE ARE 4 HANDLE POSITIONS:

- 1** - Anti-Rebound Position / In-Vehicle Position
- 2** - Carrying Position / In-Vehicle Position
- 3** - Convenience Position
(accessibility to child, non-locking position)
- 4** - Non-Rocking / Stationary Position

Push handle adjustment buttons on both sides of seat, then rotate the handle.

ALWAYS CHECK to make sure handle is locked into place after adjusting into one of the locking handle positions.

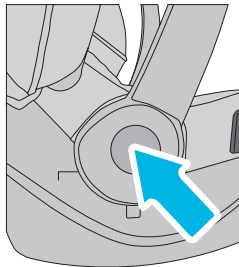
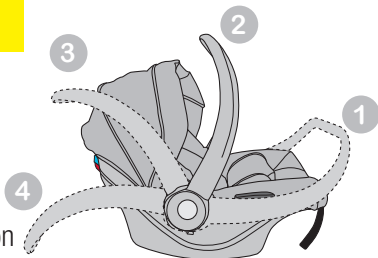

FEATURES - CANOPY

THERE ARE 2 CANOPY POSITIONS:

To open, push the canopy forward.

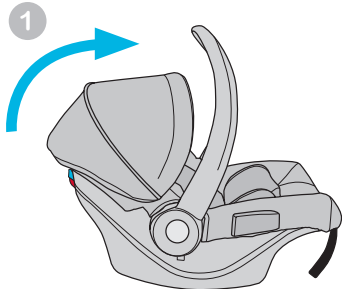

To fold, push the canopy back.

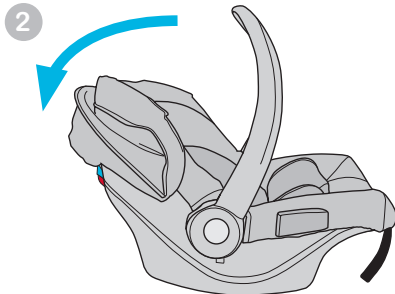

CANOPY VISOR (only on certain models):

Pull visor out from under the canopy.

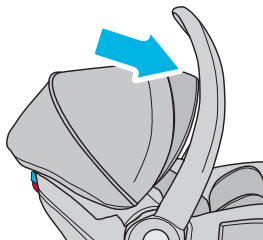

FEATURES - INFANT BODY INSERT

INFANT BODY INSERT

The infant body insert is optional for use with children from 3-11 lbs (1.4-5kg).

1 **NOTE:** Your infant car seat comes assembled with the harness installed in the second set of harness slots and the middle crotch buckle slot as shown.

Body insert is **ONLY** intended to be used when harness is in the first or second harness slots and the crotch buckle is in the inner or middle crotch buckle slots.

Discontinue use of the infant body insert when child reaches 11 lbs (5kg).

2 The back of the body insert has hook and loop straps that are threaded through the top harness slots and fastened to each other behind the shell as shown.

The hook and loop strap should only ever be inserted into the top set of harness slots.

CAUTION: NEVER use accessories or parts with this child restraint other than those approved by Summer Infant.

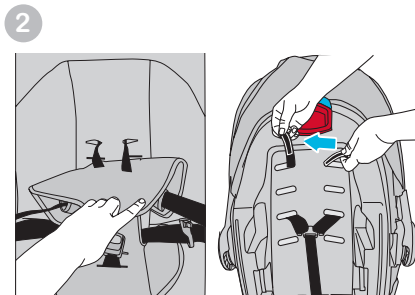
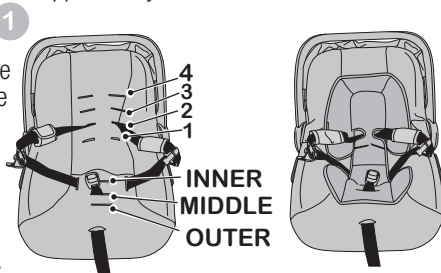

FEATURES - INFANT BODY INSERT (CONT.)

- 3 IF YOUR CHILD'S SHOULDER HEIGHT FITS HARNESS SLOT POSITION 1**, you will need to re-position the shoulder strap slots into the first set of shoulder harness slots on the insert and the inner crotch slot as shown.

Refer to **CHANGING CROTCH BUCKLE POSITION** and **CHANGING HARNESS SLOT POSITION** sections, p. 34 - 39, in order to place your straps in the correct locations.

TO REMOVE THE INFANT BODY INSERT:

Refer to the Care and Maintenance Section on pages 85-86.

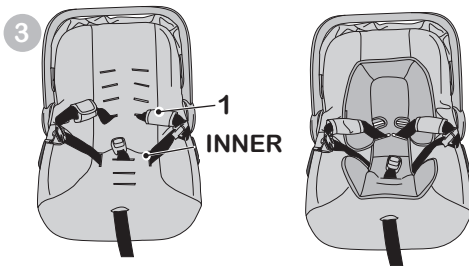

CHECKING CHILD FIT IN THE CARRIER

PLEASE REVIEW THE FOLLOWING SECTION BEFORE CHANGING YOUR HARNESS STRAP OR CROTCH BUCKLE LOCATIONS.

Depending on if your child's size, you may need to adjust the shoulder strap positions, the crotch buckle position and/or you may need to use the infant body insert.

- 1 Loosen the harness straps by pushing the harness adjuster button and pull the harness straps toward you. Open the chest clip and buckle. Rotate the handle toward the rear of seat.

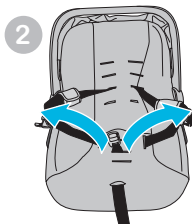
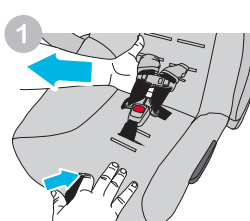

- 2 Place the harness buckle tongues and chest clip over the sides of the seat to get them out of the way to allow easier placement of child in the seat.

- 3 Place your child in the carrier with their bottom and their back flat against the seat.



CHECKING CHILD FIT IN THE CARRIER (CONT.)

- 4 Place the harness straps around your child. **MAKE SURE HARNESS STRAPS ARE AT OR JUST BELOW CHILD'S SHOULDERS** and waist straps are around the hips. **MAKE SURE** the buckle is between the child's legs. Insert the buckle tongues into the buckle as shown. **MAKE SURE** you hear each buckle tongue click into place.

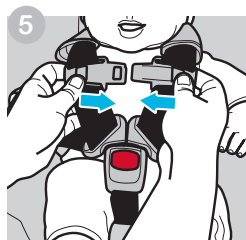
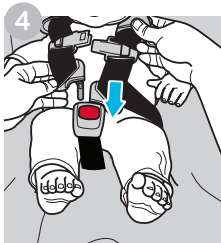

- 5 Fasten chest clip together.

Pull all the slack out from around the waist. Pull up on the harness while pushing the chest clip down. Do this on both sides.

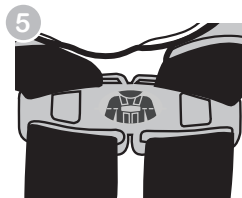

- 6 Slowly pull harness adjuster strap to make the shoulder straps snug around the child's shoulders. **BE CAREFUL. DO NOT** allow the chest clip to slide up into child's neck when tightening.

MAKE SURE to center the chest clip at armpit level. **MAKE SURE** the harness covers do not interfere with the placement of the chest clip.



CHECKING CHILD FIT IN THE CARRIER (CONT.)

- 7 CHECK that the child's head is 1" (2.5 cm) or more below the top of the seat as shown.



Hold ruler up at the top of the seat to CHECK for correct 1" (2.5 cm) spacing

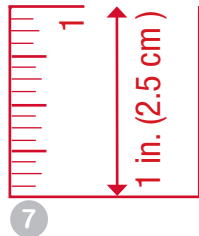

CHECKING CHILD FIT IN THE CARRIER (CONT.)

- 8 **CHECK** the harness strap and crotch buckle strap positioning on your child.
See p 34-39.

CHECK to make sure the crotch buckle strap is in the **SLOT CLOSEST TO BUT NOT UNDER YOUR CHILD**. If it is not you may need to change the crotch buckle strap position.

SEE CHANGING CROTCH BUCKLE STRAP POSITION SECTION, P. 34-35:

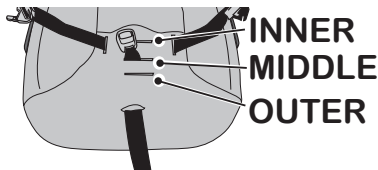

CHECK to make sure harness straps are **AT OR JUST BELOW THE CHILD'S SHOULDERS**. If it is not you may need to change the harness strap position.

SEE CHANGING HARNESS STRAP SECTION, P. 36-39.

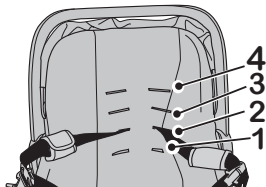

NOTE: If you have any questions at all about choosing the right slots for your size child, please contact Customer Service at 1-401-671-6551 and we will be happy to walk you through the steps!

CHANGING CROTCH BUCKLE POSITION

- 1 Turn the carrier over and push the buckle retainer through the slot.
- 2 Pull buckle strap out from the front of the seat and through the seat pad.

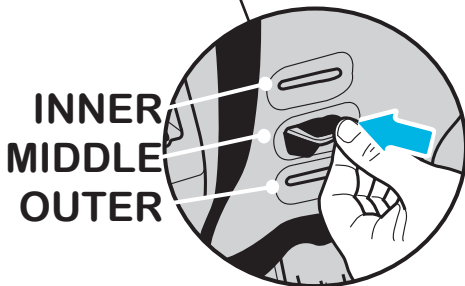
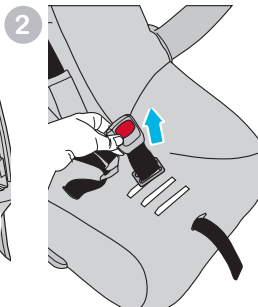
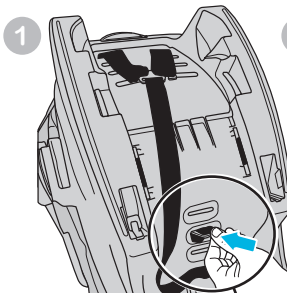

CHANGING CROTCH BUCKLE POSITION (CONT.)

- 3 Re-insert the buckle retainer through the slot that fits **CLOSEST TO BUT NOT UNDER** your child.

The retainer **MUST** go through the same set of slots in the seat pad and the carrier shell.

- 4 Pull up on the buckle strap from the front of the seat to make sure the strap is secured on the bottom of the seat shell and not on the bottom of the seat pad.

CHECK to make sure the red button on buckle is visible as shown.

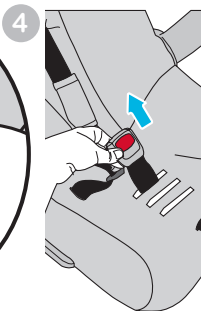

CHANGING HARNESS STRAP POSITION

- 1 Loosen the harness straps by pushing the harness adjuster button under the seat pad while pulling the straps out.

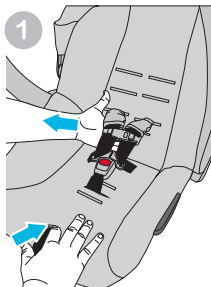

- 2 Turn the carrier over.

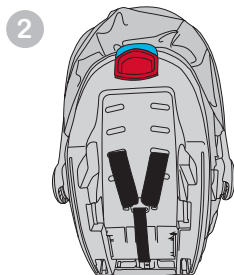

- 3 Slide the harness straps off the splitter plate.

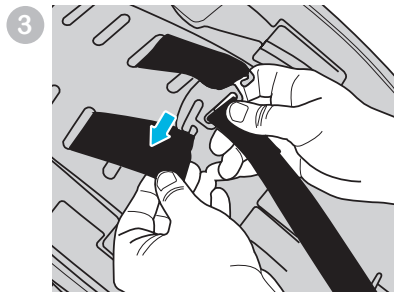

CHANGING HARNESS STRAP POSITION (CONT.)

- 4 Pull the straps through the front of the seat and the seat pad.
- 5 **BEFORE** inserting the harness straps back through the seat pad, if you need to use the infant body insert in harness slot Position 1, you will need to thread the harness strap through the first set of harness slots on the insert as shown before inserting the straps through the seat pad and seat shell.

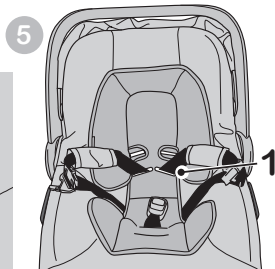
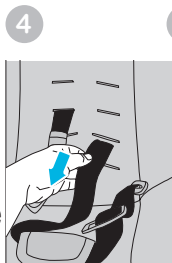

- 6 If you are not using the infant body insert, re-insert the harness straps into the appropriate slots for your child so that the harness is **AT OR JUST BELOW THE CHILD'S SHOULDERS**. When inserting the harness straps back through the seat pad, **MAKE SURE** they are inserted into the same set of slots in the seat pad and the shell.

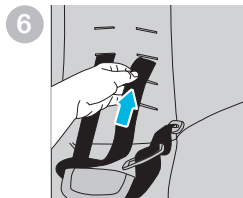

CHANGING HARNESS STRAP POSITION (CONT.)

- 7 Before attaching the harness straps onto the splitter plate, determine which set of harness loops you need.

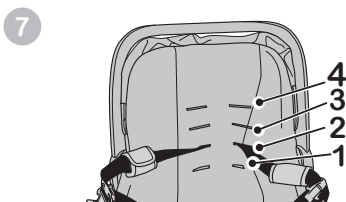

If your harness straps are inserted into Harness Slot Positions 2, 3 or 4 use the end loops.

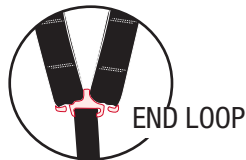

If your child is under 8 lbs (3.6 kg) and the harness is in Harness Slot Position 1, place the harness straps on the inner loop.



CHANGING HARNESS STRAP POSITION (CONT.)

- 8 Insert straps onto splitter plate.

MAKE SURE they are completely attached onto the splitter plate.

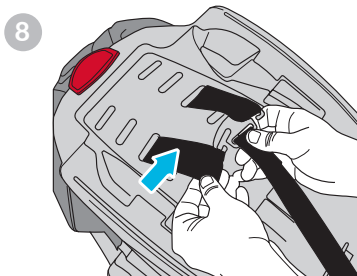

- 9 When using the INNER LOOPS. **DO NOT** place the harness straps behind the splitter plate. Harness straps should lie in front of splitter plate as shown.

- 10 **CHECK** to make sure the harness straps are attached by lifting up the straps as shown.

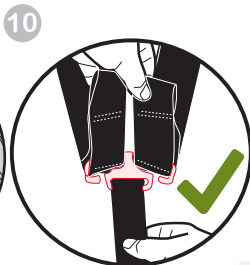

SECURING YOUR CHILD IN THE INFANT CARRIER

- 1 Rotate handle out of the way. Push the harness adjuster button and pull the harness straps toward you.
- 2 Push button on the buckle to release the buckle tongues
- 3 Open the chest clip by pressing the buttons as shown. Separate the two pieces as shown and move the straps out of the way.
- 4

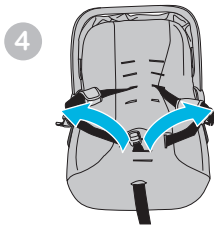
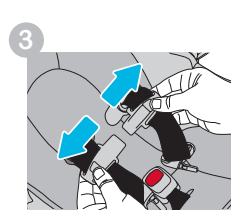
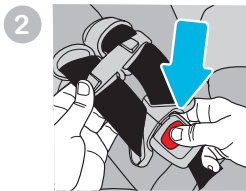
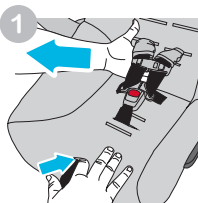

- 5 Place your child in the carrier with their bottom and their back flat against the seat.



SECURING YOUR CHILD IN THE INFANT CARRIER

- 6 Place the harness straps around your child. **MAKE SURE HARNESS STRAPS ARE AT OR JUST BELOW CHILD'S SHOULDERS** and waist straps are around the hips. **MAKE SURE** the buckle is between the child's legs.

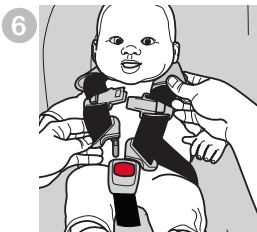

- 7 Insert the buckle tongues into the buckle as shown. **MAKE** sure you hear each buckle tongue click into place. **DO NOT** use child restraint if buckle tongues **DO NOT** click into the buckle. If the tongues do not click into the buckle, try cleaning the buckle, see pg. 90. If this does not fix the problem, please call Customer Service before using the child restraint.

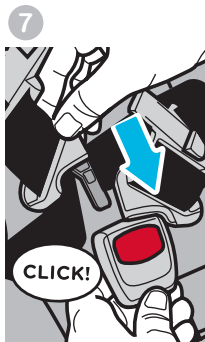

- 8 Fasten chest clip together.

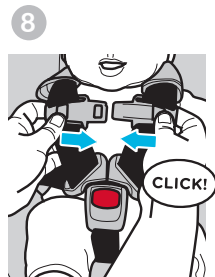

SECURING YOUR CHILD IN THE INFANT CARRIER

- 9 Pull all the slack out from around the waist. Pull up on the harness while pushing the chest clip down. Do this on both sides.
- 10 Slowly pull harness adjuster strap to make the shoulder straps snug around the child's shoulders. A snug strap should not allow any slack. It lies in a relatively straight line without sagging. It does not press on the child's flesh or push the child's body into an unnatural position.
BE CAREFUL. DO NOT allow the chest clip to slide up into child's neck when tightening.
- 11 MAKE SURE to center the chest clip at armpit level. MAKE SURE the harness covers do not interfere with the placement of the chest clip.

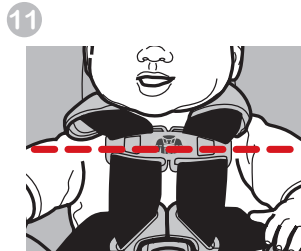
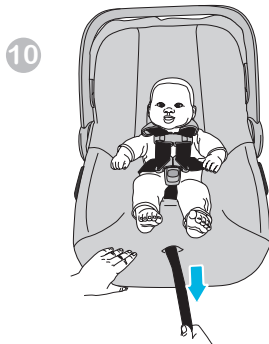
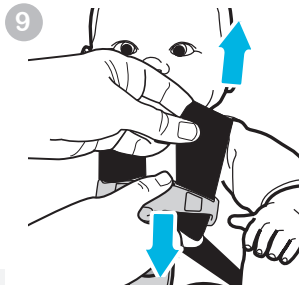

SECURING YOUR CHILD IN THE INFANT CARRIER

CHECK STEP:

- MAKE SURE the straps are snug, lie flat, and not twisted. If you can pinch a fold in the strap it is not snug.
- Harness Tightness Test. To test for a properly tightened harness, pinch the shoulder strap. A snug harness should not allow you to pinch any slack when pinched between your thumb and forefinger. If needed, pull adjuster strap further for a tight and proper fit.
- MAKE SURE child's head is 1" (2.5 cm) below the top of the seat.



Minimum 1 inch (2.5 cm)



- NEVER secure child in infant carrier dressed in a bulky garment or heavy clothing, it may interfere with tightening the harness.
- If the harness covers don't allow a proper fit, they can be removed to provide more space for the chest clip. Unfasten harness covers and remove.

REMOVING YOUR CHILD FROM THE CARRIER

- 1 Loosen harness by firmly pressing down the harness adjuster button while pulling forward on both straps.

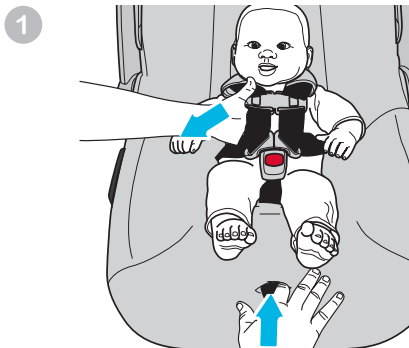

- 2 Push the red buckle release button and remove the buckle tongues.

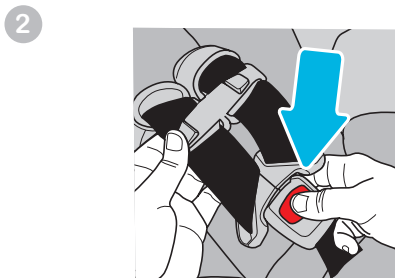

REMOVING YOUR CHILD FROM THE CARRIER

- 3 Press the two buttons on the chest clip and unfasten it.

3

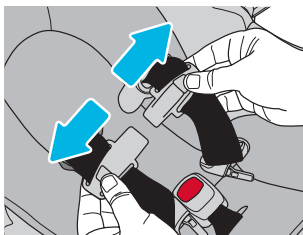



LATCH USAGE

LATCH is an acronym for Lower Anchors and Tethers for Children and refers to a pair of fixed Lower Anchors (or metal bars) and a Top Tether anchor that are built into your vehicle, in vehicles built after September 1, 2002.

The lower **LATCH** anchors are located in the seat bight, between the vehicle seat back and the seat cushion. If they are not visible, they will typically be indicated by  symbols. Top tether anchors are located in various places behind the rear vehicle seat.

NOTE: The Summer Infant Affirm™ 335 does not require use of a tether strap. ONLY the lower anchors are used with this child restraint.

This child restraint can be safely installed using either lower anchors or vehicle belts and meets the requirements of Federal Safety Standard FMVSS 213 with either installation method. Either method is safe for your child when installed correctly.

Refer to your vehicle Owner's Manual for lower **LATCH** anchor positions (if available) in your vehicle.

NEVER use **LATCH** together with the vehicle belts to install this child restraint. Using both is not approved and may affect the performance of the child restraint.

NEVER use two **LATCH** hooks on the same vehicle lower anchor or (metal bars).

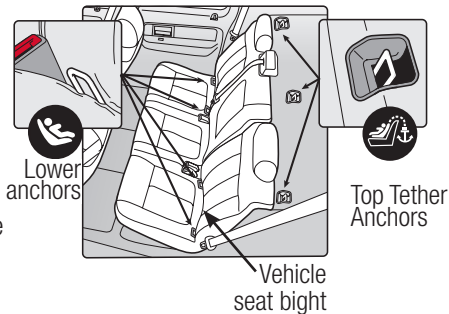



LATCH USAGE

Center Seating Positions

If your vehicle does not have lower anchors in the center seating position, check your vehicle owner's manual to see if you are allowed to use the two inner lower anchors from the outboard seating positions to install a child restraint.

Summer Infant allows this child restraint to be installed using the two inner lower anchors from the outboard seating positions if the distance between the inner lower anchors is between 11 and 20 inches (28-51 cm) AND if your vehicle manufacturer allows it. (NOTE: If distance is not correct and/or not allowed by vehicle manufacturer, use the vehicle belt for installation in the center position.)

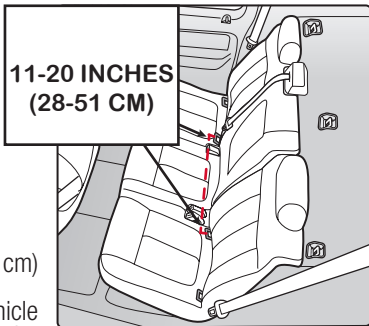

VEHICLE SEATING LOCATIONS

! WARNING! DEATH or SERIOUS INJURY can occur,

FAILURE TO PLACE THE CHILD RESTRAINT IN A CORRECT SEATING POSITION INCREASES THE RISK OF SERIOUS INJURY OR DEATH.

DO NOT place rear-facing child seat on front seat with air bag. **DEATH OR SERIOUS INJURY** can occur. The back seat is the safest place for children 12

and under. Owners of vehicles with airbags should refer to their owner's manual for child restraint installation instructions.

REAR FACING



SIDE FACING



NEVER place the child restraint on any vehicle seat that is not in a locked position. Folding seats can fall forward and could cause serious injury to your child in a vehicle crash.

NOTE: The Affirm™335 is allowed to touch the vehicle seat(s) in front of it, as long the recline angle of the child restraint is not affected.

The best position for the child restraint is one that is recommended by your vehicle Owner's Manual AND allows a proper and secure installation of the restraint every time.

The vehicle seat **MUST** FACE FORWARD.

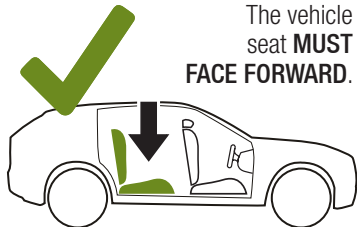



SAFE VEHICLE BELT TYPES THAT CAN BE USED

If you have any of these types of vehicle belt systems listed, these are **SAFE** to use to install your child restraint in the vehicle. Review vehicle owner's manual for specific instructions on child restraint installation. **LATCH** can be used **IN PLACE OF** these vehicle belt types. Refer to your vehicle owner's manual for **LATCH** locations.



Lap Belt with Locking Latch Plate

Once buckled, the vehicle belt is tightened by pulling on the free end of the strap until the belt is tight.

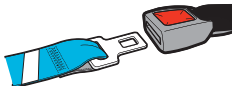

Lap Belt with Automatic Locking Retractor (ALR)

The automatic locking retractor does not allow the lap belt to get longer once it is buckled. The vehicle belt is tightened by feeding seat belt webbing into retractor.

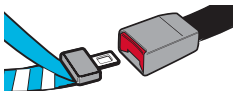

Lap/Shoulder Belt with Locking Latch Plate

The lap portion of this belt does not loosen once the belt is buckled. The vehicle belt is tightened by pulling up hard on shoulder belt and feeding the extra webbing into the retractor.

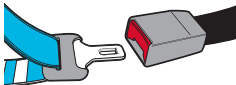

Lap/Shoulder Belt with Sliding Latch Plate with Locking Retractor

The latch plate slides freely along the lap/shoulder belt. Vehicle belts with sliding latch plates are typically locked at the shoulder belt retractor by buckling the belt and pulling all of the webbing out slowly to switch the retractor. Check vehicle owner's manual for specific instructions. The vehicle belt is tightened after switching the retractor by pulling shoulder belt all the way out and feeding the webbing into the retractor.

UNSAFE - VEHICLE BELT TYPES THAT CANNOT BE USED

NEVER use any of these to install your child restraint in the vehicle. These vehicle belt systems are **UNSAFE** to use to install your child restraint in the vehicle.

If available, **LATCH** can be used **IN PLACE OF** these vehicle belt types. Refer to your vehicle owner's manual for **LATCH** locations.

NEVER INSTALL THIS CHILD RESTRAINT WITH ANY OF THE FOLLOWING VEHICLE BELTS:

- **Motorized/Vehicle** seat belts



- **Vehicle belts that are attached to the door** in any way, or that move along a track automatically to restrain the passenger when the door is closed.



UNSAFE - VEHICLE BELT TYPES THAT CANNOT BE USED

- **Lap/Shoulder Belts with 2 Retractors**

(unless lap belt has a lock mode)

Belts are attached to retractors at the ends of the lap and shoulder belt and attached to one latch plate.

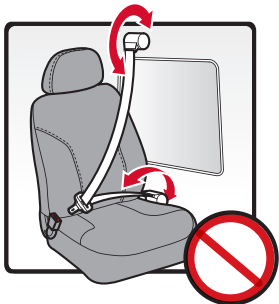

- **Lap belts with an Emergency Locking Retractor (ELR).**

These lap belts stay loose and can move until locking in a crash or sudden stop.



- **Inflatable Seat Belts**





BASE INSTALLATION WITH LATCH (LOWER ANCHORS)

BEFORE installing base, make sure vehicle is on level ground. Place base on an approved **LATCH** vehicle seating location.



- 1 Rotate handle on base to open the Belt Tensioning Arm all the way up.
- 2 Remove **LATCH** straps from **LATCH** storage.
- 3 Extend the strap to its longest length.

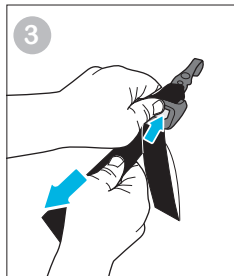
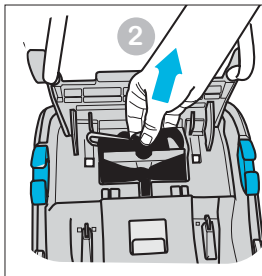
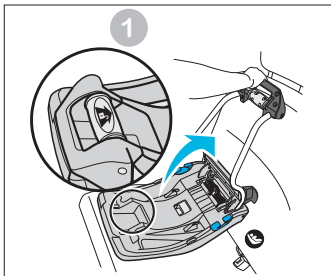



BASE INSTALLATION WITH LATCH (LOWER ANCHORS) (CONT.)

- 4 Route the **LATCH** belt through the BLUE belt guides on both sides of the base. **MAKE SURE** not to twist the belt and make sure it lies flat.
Adjust the recline foot to achieve correct angle, see p. 77.
Push base against vehicle seat back. Attach both **LATCH** Connectors to the lower **LATCH** anchors. **CHECK** to make sure they are attached to vehicle anchors on both sides of the base by pulling on the **LATCH**.
- 5 Pull on the **LATCH** strap to take the slack out, just enough to make it snug but **DO NOT OVER-TIGHTEN!** The Belt Tensioning Arm will fully tighten the system.
- 6 Close the belt tensioning arm. (If you have difficulty closing the arm, the **LATCH** belt may be too tight. Open the arm, loosen **LATCH** belt slightly and close and lock the arm.)

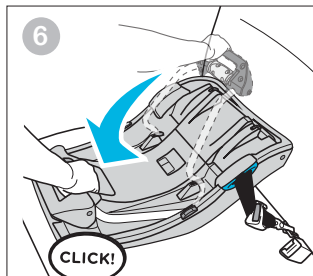
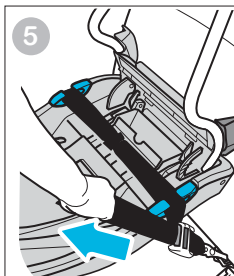
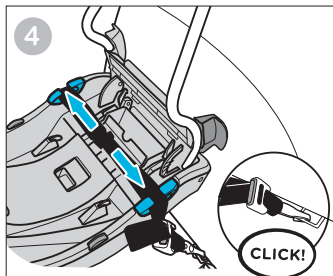



BASE INSTALLATION WITH LATCH (LOWER ANCHORS) (CONT.)

- 7 **CHECK** to make sure base is secure by holding both sides of the base near the belt guides and moving from side to side and front to back. The **LATCH** belt should not loosen or move easily. The base should not move more than 1 inch (2.54cm) from side to side or front to back. If base moves too much, open arm, tighten strap a little more, then try again. If base still moves try another seating location or installation method.
- 8 **CHECK** the level indicator to make sure the base is correctly reclined. **IF IT IS NOT** properly reclined, turn the handle and open the Belt Tensioning Arm, remove the **LATCH** hooks and adjust the foot on the base then re-install base. **CHECK** that the base is properly reclined. Refer to Adjust the Recline Angle, p. 77.

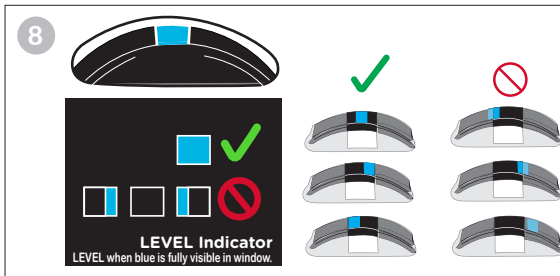
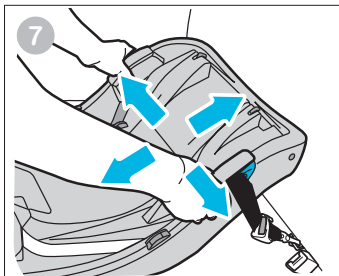



BASE INSTALLATION WITH LATCH (LOWER ANCHORS) (CONT.)

- 9 Insert the carrier into the base until you hear a click. Re-check the level indicator.

- 10 **ALWAYS** lift up on the carrier to be sure that it is securely in the base.

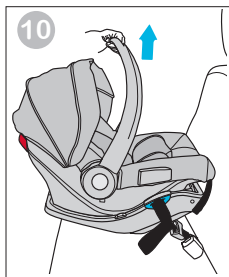
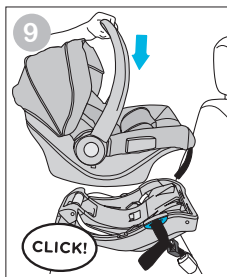

- 11 **Recommended:**
Squeeze both handle adjustment buttons and lower handle to Position 1.

- 12 To remove carrier from the base, raise the handle to position 2, squeeze the handle release at the back of the carrier and lift up.

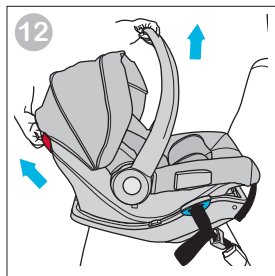
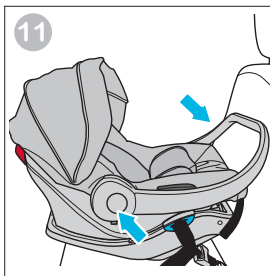



BASE REMOVAL WITH LATCH (LOWER ANCHORS)

- 13** TO REMOVE BASE, turn the handle and open the belt tensioning arm.

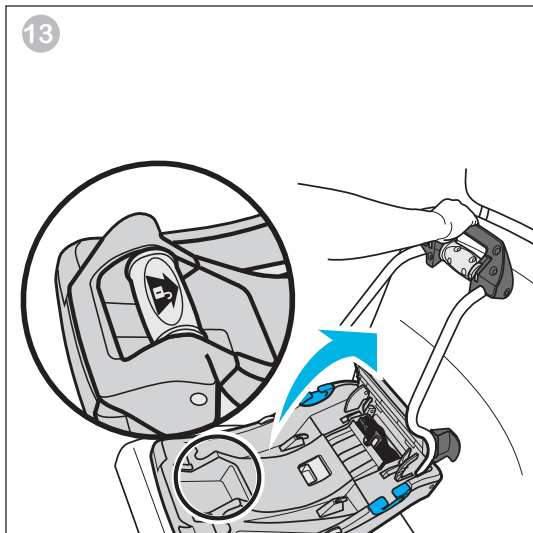



BASE REMOVAL WITH LATCH (LOWER ANCHORS) (CONT.)

- 14 Squeeze the clip then push the hook towards the seat, lift or twist hook out from the vehicle **LATCH** anchor. You may need to further loosen the tension on the **LATCH** strap by pushing the **LATCH** strap adjustment button and pulling on the strap. Repeat on other side of base.
- 15 **When storing**, place the **LATCH** strap and hooks inside the **LATCH** storage. Insert the straps on either side of the storage area in the designated slots. **NEVER** allow straps to lie outside the storage area when **LATCH** is not in use as it may interfere with the carrier latching to the base.

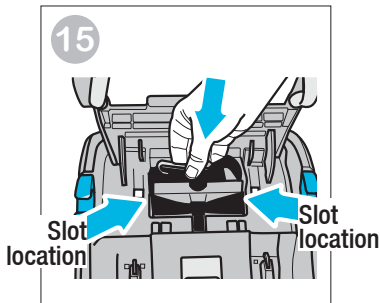
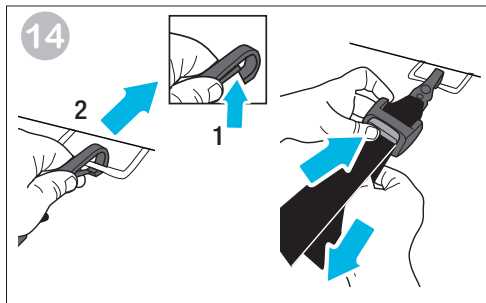



BASE INSTALLATION WITH VEHICLE LAP/SHOULDER BELT

BEFORE installing base, make sure vehicle is on level ground. Place base on an approved vehicle seating location. Make sure the **LATCH** straps are stored in the storage area.



- 1 Position base on the rear vehicle seat so that it touches the vehicle seat back.

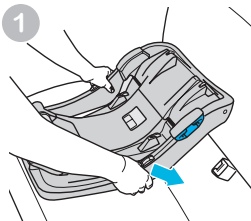

Adjust the recline foot to get the correct recline angle, see pg. 77.

- 2 Rotate handle on base to open the Belt Tensioning Arm.

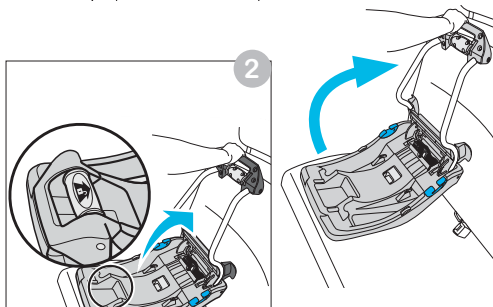



BASE INSTALLATION WITH VEHICLE LAP/SHOULDER BELT

- 3 Route the **lap/shoulder** belt through the BLUE belt guides on both sides of the base. **MAKE SURE** not to twist the belt and make sure it lies flat.

MAKE sure the **lap/shoulder** belt is routed through both blue belt guides on either side of the base. **BUCKLE** the belt.

- 4 Close the belt tensioning arm. Lock the vehicle shoulder belt by pulling shoulder belt all the way out then feeding back into retractor.

- 5 In some vehicles, there may be a folded piece of webbing or a plastic button on the lap/shoulder belt.

If during installation the folded webbing or plastic button interfere with the belt guide or the belt tensioning arm, you may need to adjust the recline foot as long the base is still level or move the base to another seating location.

If this does not help you may need to try a different installation method such as **LATCH**.

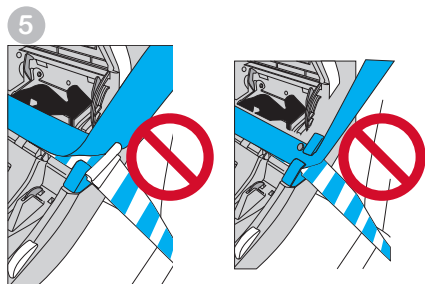
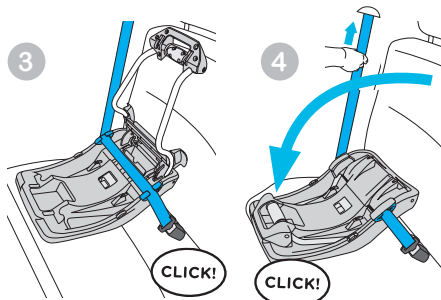



BASE INSTALLATION WITH VEHICLE LAP/SHOULDER BELT

- 6 Grab the base at the belt guides and pull from side to side and front to back to make sure it is installed correctly. The base should not move more than 1 inch (2.5 cm) in any direction.

If the base moves too much, open the belt tensioning arm and remove a little more slack from the vehicle belt, close arm and re-check. After this, if the base still moves too much, you may need to try a different vehicle seat location or installation method, or both.

You can switch the shoulder belt retractor into locking mode by pulling out shoulder belt all the way and then letting it rewind into the retractor. Pull on the belt to make sure it is locking.

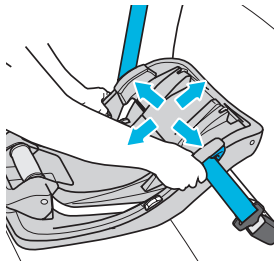



BASE INSTALLATION WITH VEHICLE LAP/SHOULDER BELT

- 7 Insert the carrier into the base until you hear a click. Re-check the level indicator. If not level, remove carrier, adjust recline angle and re-install. See pg. 77.

ALWAYS lift up on the carrier to be sure that it is securely in the base.

- 8 Squeeze both handle adjustment buttons and lower handle to Position 1 if desired.

To remove carrier from the base, squeeze the handle release at the back of the carrier.
To remove base, open belt tensioning arm and unbuckle from the vehicle seat.

7



8

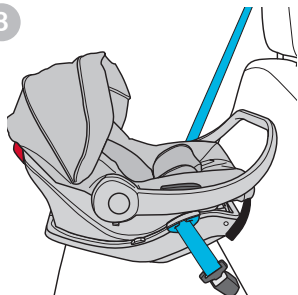



BASE INSTALLATION WITH VEHICLE LAP BELT

BEFORE installing base, make sure vehicle is on level ground. Place base on an approved vehicle seating location. Make sure the **LATCH** straps are stored in the storage area.



- 1 Position Base on a rear vehicle seat so that it touches the vehicle seat back.

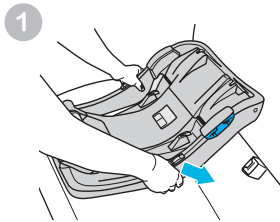

Adjust the recline foot to get the correct recline angle, see pg. 77.

- 2 Rotate handle on base to open the belt tensing arm.

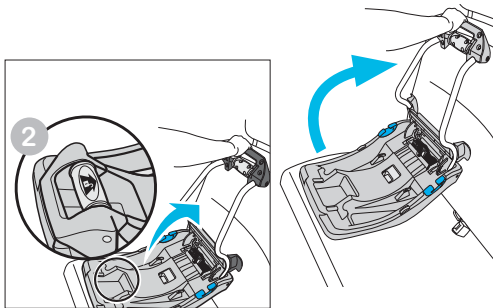



BASE INSTALLATION WITH VEHICLE LAP BELT

- 3 Route the **lap** belt through the BLUE belt guides on both sides of the base.
MAKE SURE not to twist the belt and make sure it lies flat.
MAKE sure the lap belt is routed through both blue belt guides on either side of the base. BUCKLE the belt.
Pull the seat belt tightly to remove all the slack from it.

- 4 Close the Belt tensioning arm.

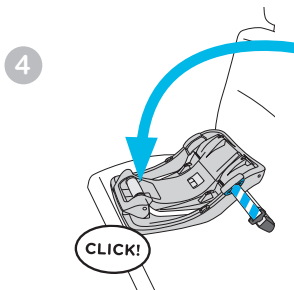
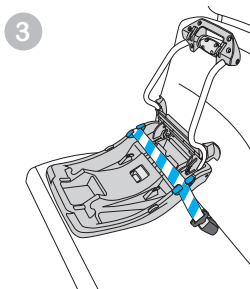



BASE INSTALLATION WITH VEHICLE LAP BELT

- 5 Grab the base at the belt guides and pull from side to side and front to back to make sure it is installed correctly. The Base should not move more than 1 inch (2.5 cm) in any direction.

If the base moves too much, open the belt tensioning arm and remove a little more slack from the vehicle belt, close arm and re-check. After this, if the base still moves too much, you may need to try a different vehicle seat location or installation method, or both.

5

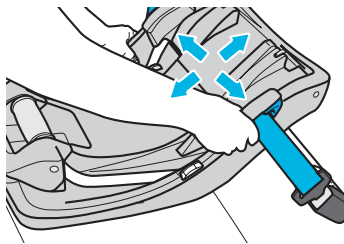



BASE INSTALLATION WITH VEHICLE LAP BELT

- 6 Insert the carrier into the base until you hear a click. Re-check the level indicator. If not level, remove carrier, adjust recline angle and re-install. See page 77.

ALWAYS lift up on the carrier to be sure that it is securely in the base.

- 7 Squeeze both handle adjustment buttons and lower handle to Position 1 if desired.

To remove carrier from the base, squeeze the handle release at the back of the carrier.

To remove base, open belt tensioning arm and unbuckle from the vehicle seat.

MAKE SURE the handle is locked in Position 2 before carrying the child restraint.

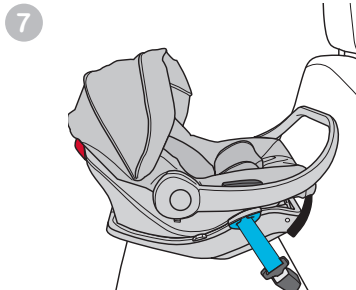
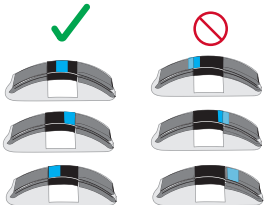



CARRIER INSTALLATION WITHOUT THE BASE WITH THE VEHICLE LAP/SHOULDER BELT AND **SHOULDER BELT GUIDE**

NEVER install this child restraint using a non-locking vehicle lap shoulder belt. (See pg. 50-51) A locking clip must be used with a vehicle belt that **DOES NOT LOCK**.
Call Summer Infant Customer Service at 1-401-671-6551 to obtain a locking clip.

Make sure vehicle is on level ground.

- 1 Place child in the carrier, refer to Securing Your Child in the Infant Carrier section, p. 40-43.

Position the infant carrier on a rear vehicle seat, with the handle in **Position 2** (see pg. 26), with the foot end towards the vehicle seat back, push it firmly against the vehicle seat.

- 2 Route the lap belt portion of the vehicle belt into the belt guides on the carrier. Make sure the vehicle belt is correctly routed on both sides and the belt is not twisted.

NEVER route the shoulder belt through the vehicle belt guides on the sides of seat.

Fasten the buckle.

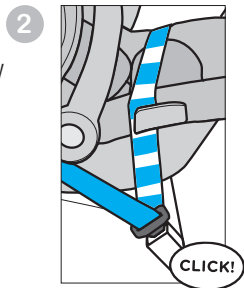
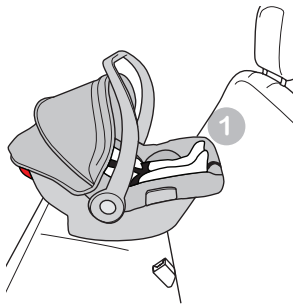



CARRIER INSTALLATION WITHOUT THE BASE WITH THE VEHICLE LAP/SHOULDER BELT AND **SHOULDER BELT GUIDE**

- 3 Lift shoulder belt over handle and around carrier. Make sure not to twist vehicle shoulder belt.

Slide shoulder belt into the blue Shoulder Belt Guide on rear of seat.

Refer to your vehicle Owner's Manual for how your vehicle lap and shoulder belt locks.

In many vehicles, you can switch the shoulder belt retractor into locking mode by pulling the shoulder belt out all the way and then letting it go back in. You will hear a clicking sound. **CHECK** to make sure its locked by pulling on it.

To check if the vehicle belt is locked, pull out on the shoulder belt. The belt should remain tight if the vehicle system is locked.

- 4 Push infant carrier firmly back and down towards the vehicle seat as you tension the belt by pulling on the shoulder belt portion then feed excess belt into the retractor.

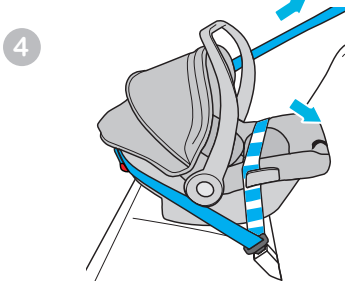
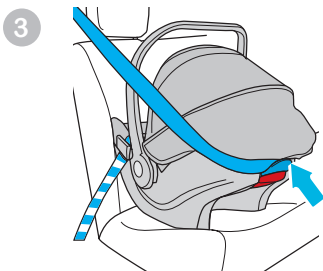



CARRIER INSTALLATION WITHOUT THE BASE WITH THE VEHICLE LAP/SHOULDER BELT AND **SHOULDER BELT GUIDE**

- 5 Check the recline angle. Adjust the seat angle until the red line on the infant carrier is level with the ground. A tightly rolled towel or pool noodle may be placed under the infant carrier near the vehicle seat back to adjust the angle. See p. 78-79.

The carrier is allowed to touch the vehicle seat(s) in front of it, as long as the recline angle of the car seat is not affected.

- 6 Grab the infant carrier at the belt guides and pull from side to side and front to back to make sure it is installed correctly. The infant carrier should not move more than 1 inch (2.5 cm) in any direction.

If the infant carrier moves too much, tighten the vehicle belts more and re-check. You may need to try a different vehicle seat location or installation method, or both.

- 7 Push buttons on side of handle to adjust handle to either Position 1 or 2. Either position may be used in vehicle, see p. 26.

5



6

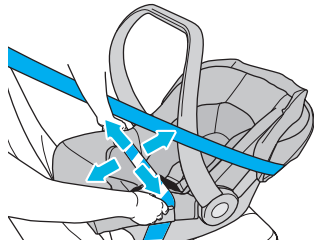

7

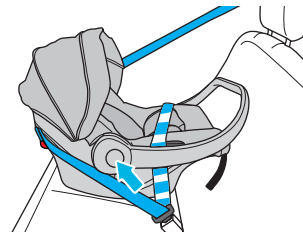



CARRIER INSTALLATION WITHOUT THE BASE WITH THE VEHICLE LAP/SHOULDER BELT AND **SHOULDER BELT GUIDE**

- 8 To remove, unbuckle vehicle seat belt and carefully remove from vehicle belt guides on infant carrier.
- 9 Unhook vehicle belt from shoulder belt guide on back of infant carrier.

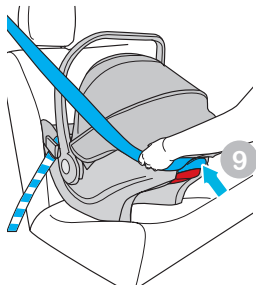
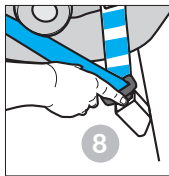

- 10 Place carrier handle in Position 2 and lift infant carrier out of vehicle with both hands.

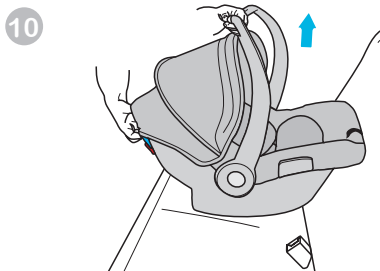



CARRIER INSTALLATION WITHOUT THE BASE WITH THE LAP/SHOULDER BELT

NEVER install this child restraint using a non-locking vehicle lap shoulder belt. (See page p.50-51) A locking clip must be used with a vehicle belt that **DOES NOT LOCK**.
Call Summer Infant Customer Service at 1-401-671-6551 to obtain a locking clip.

Make sure vehicle is on level ground.

- 1 Place child in the carrier, refer to Securing Your Child in the Infant Carrier section, p. 40-43.

Position the infant carrier on a rear vehicle seat, with the handle in **Position 2** (see pg. 26), with the foot end towards the vehicle seat back, push it firmly against the vehicle seat.

- 2 Route the lap belt portion of the vehicle belt into the belt guides on the carrier. Make sure the vehicle belt is correctly routed on both sides and the belt is not twisted.

NEVER route the shoulder belt through the vehicle belt guides on sides of seat.

Fasten the buckle.

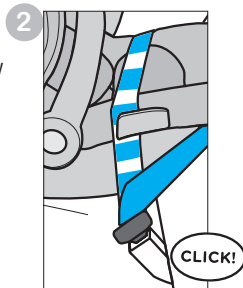
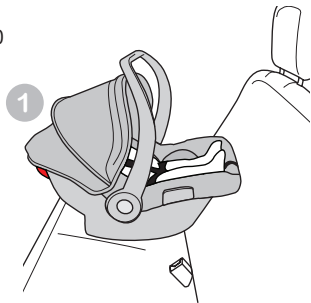



CARRIER INSTALLATION WITHOUT THE BASE WITH THE LAP/SHOULDER BELT

Refer to your vehicle Owner's Manual for how your vehicle lap and shoulder belt locks.

In many vehicles, you can switch the shoulder belt retractor into locking mode by pulling the shoulder belt out all the way and then let it go back in. You will hear a clicking sound. CHECK to make sure its locked by pulling on it.

To check if the vehicle belt is locked, pull out on the shoulder belt. The belt should remain tight if the vehicle system is locked.

- 3 Push infant carrier firmly back and down towards the vehicle seat as you tension the belt by pulling on the shoulder belt portion then feed excess belt into the retractor.

3

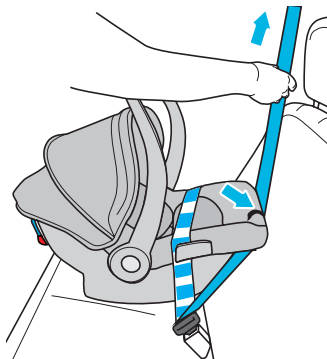



CARRIER INSTALLATION WITHOUT THE BASE WITH THE LAP/SHOULDER BELT

- 4 Check the recline angle. Adjust the seat angle until the red line on the infant carrier is level with the ground. A tightly rolled towel or pool noodle may be placed under the infant carrier near the vehicle seat back to adjust the angle. See page p.78-79.

The carrier is allowed to touch the vehicle seat(s) in front of it, as long the recline angle of the car seat is not affected.

- 5 Grab the infant carrier at the belt guides and pull from side to side and front to back to make sure it is installed correctly. The Infant Carrier should not move more than 1 inch (2.5 cm) in any direction.

If the infant carrier moves too much, tighten the vehicle belts more and re-check. You may need to try a different vehicle seat location or installation method, or both.

- 6 Push buttons on side of handle to adjust handle to either Position 1 or 2. Either position may be used in vehicle, see p. 26.

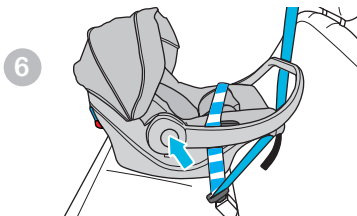
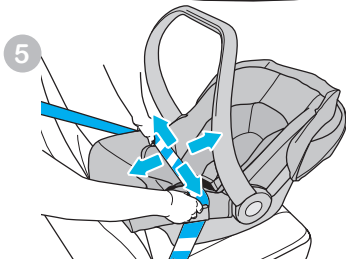



CARRIER INSTALLATION WITHOUT THE BASE WITH THE LAP/SHOULDER BELT

To remove, unbuckle vehicle seat belt and carefully remove from vehicle belt guides on infant carrier.

- 7 Place carrier handle in Position 2 and lift infant carrier out of vehicle with both hands.

7

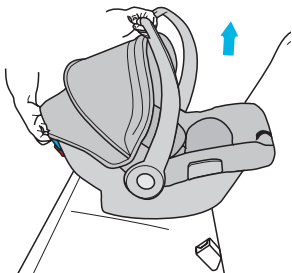



CARRIER INSTALLATION WITHOUT THE BASE WITH THE LAP BELT

1

Make sure vehicle is on level ground.

Place child in the carrier, refer to *Securing Your Child in the Infant Carrier* section, p. 40-43.

Position the infant carrier on a rear vehicle seat, with the handle in **Position 2** (see pg. 26), with the foot end towards the vehicle seat back, push it firmly against the vehicle seat.

Route the lap belt portion of the vehicle belt into the belt guides on the carrier. Make sure the vehicle belt is correctly routed on both sides and the belt is not twisted. Fasten the buckle.

Push infant carrier firmly back and down towards the vehicle seat as you tension the belt by pulling on the free end of the lap belt strap.

If necessary, tuck the loose end of the lap belt out of the way.

2

Check the recline angle. Adjust the seat angle until the red level line on the infant carrier is level with the ground. A tightly rolled towel or pool noodle may be placed under the infant carrier near the vehicle seat back to adjust the angle. See pg. 78-79.

1



CLICK!

2



Look for this label on the shell

RED line MUST be level with the ground when the child restraint is installed WITHOUT the base.

000000000 019



CARRIER INSTALLATION WITHOUT THE BASE WITH THE LAP BELT

The carrier is allowed to touch the vehicle seat(s) in front of it, as long as the recline angle of the car seat is not affected.

- 3 Grab the infant carrier at the belt guides and pull from side to side and front to back to make sure it is installed correctly. The Infant Carrier should not move more than 1 inch (2.5 cm) in any direction.

If the infant carrier moves too much, tighten the vehicle belts more and re-check. You may need to try a different vehicle seat location or installation method, or both.

- 4 Push buttons on side of handle to adjust handle to either Position 1 or 2.

Either position may be used in vehicle, see p. 26.

To remove carrier from vehicle, unbuckle belt.

3

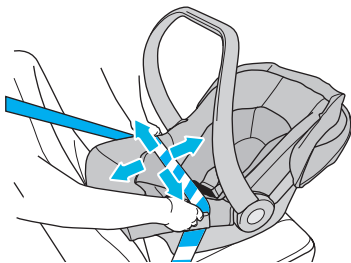

4

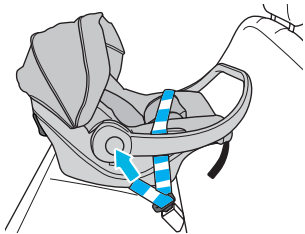

ADJUSTING THE RECLINE

WARNING

Failure to properly recline the child restraint on the vehicle seat increases the risk of death or serious injury.

It is very important for your child's safety that this child restraint be installed at the correct recline angle. Before attaching the infant carrier to the base, always check the level indicator for the correct recline angle.

DO NOT use this or any other child restraint with a premature, low birth weight, or medically fragile infant, until after you have consulted with your doctor. Some infants may have difficulty breathing or have other medical problems when placed in a seated position.

If the child restraint is **TOO UPRIGHT**, the child's head may fall forward and cause breathing problems.

If the child restraint is **TOO RECLINED** crash protection will be reduced.

CHECKING THE RECLINE WITH THE BASE

To Adjust Recline Angle

- 1 Pull up the recline adjustment lever while holding the front of base. Extend or retract the recline foot until blue square is fully visible in the level indicator window. IF BLUE SQUARE IS NOT FULLY VISIBLE IN WINDOW, BASE IS NOT LEVEL.
- 2

Release handle to lock foot into one of the 4 recline positions.

Install Base. Be sure to check for correct recline angle after installation.

If the recline angle is not correct after installation, uninstall the base, adjust recline foot and re-install.

There are four recline positions:

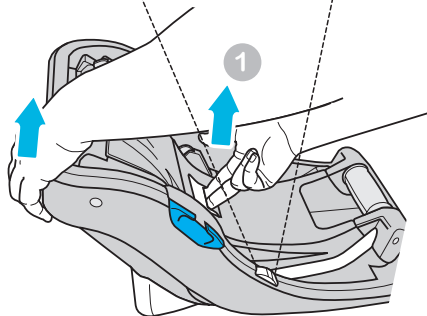
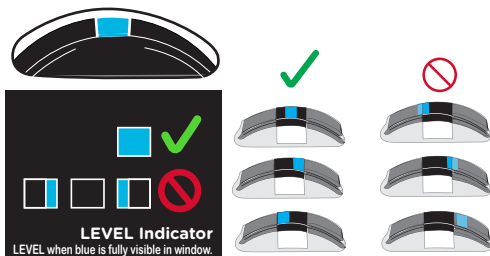
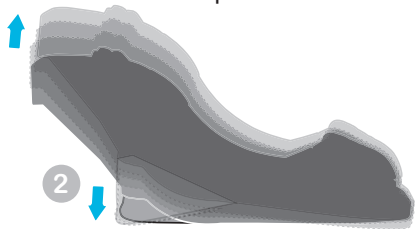

ADJUSTING THE RECLINE ANGLE WITHOUT THE BASE

! WARNING

Failure to properly recline the child restraint on the vehicle seat increases the risk of death or serious injury.

It's very important for your child's safety that this child restraint be installed at the correct angle.

DO NOT use this or any other child restraint with a premature, low birth weight, or medically fragile infant, until after you have consulted with your doctor. Some infants may have difficulty breathing or have other medical problems when placed in a seated position.

If the child restraint is **TOO UPRIGHT**, the child's head may fall forward and cause breathing problems.

If the child restraint is **TOO RECLINED** crash protection will be reduced.

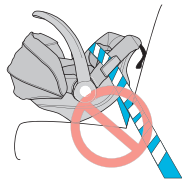
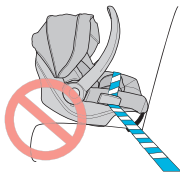

ADJUSTING THE RECLINE ANGLE WITHOUT THE BASE

To Adjust Recline

MAKE SURE vehicle is on level ground.

Adjust the seat angle until the red level line on the label on the infant carrier is level with the ground.

If you are having trouble achieving the proper recline angle:

- Un-install the Infant Carrier.
- Place a tightly rolled towel or pool noodle under the infant carrier's foot end where indicated. Re-install the carrier.

NEVER place a rolled towel or blanket at the head end of the infant carrier.

If carrier is on an aircraft, a tightly rolled airline blanket may be placed under the infant carrier to adjust the angle.

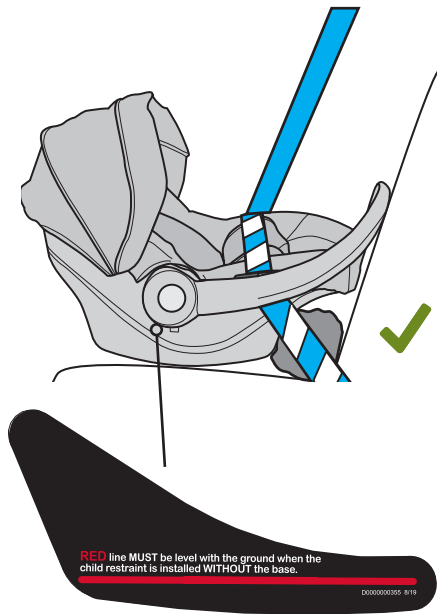



USING THE INFANT CARRIER ON AN AIRCRAFT

The FAA recommends that children up to 40 pounds (18 kg) use a certified, harnessed child seat while traveling on an airplane. The Affirm™ 335 is certified for airplane use only **WITHOUT** the base.

DO NOT install in an aircraft seat that is equipped with an inflatable seat belt.

BEFORE installing carrier, refer to the Securing Your Child in the Infant Carrier section to secure your child in the carrier, pg 40-43.

- 1 **MAKE SURE** the airline seat is in the fully upright position.

Position infant carrier rear-facing in aircraft seat with the foot end firmly against the back of the aircraft seat.

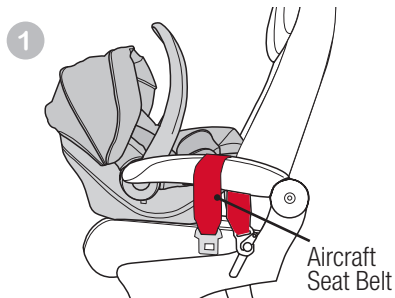



USING THE INFANT CARRIER ON AN AIRCRAFT

- 2 Place child in the carrier and secure harness. Route lap belt under both vehicle belt guides. **BUCKLE THE BELT.**

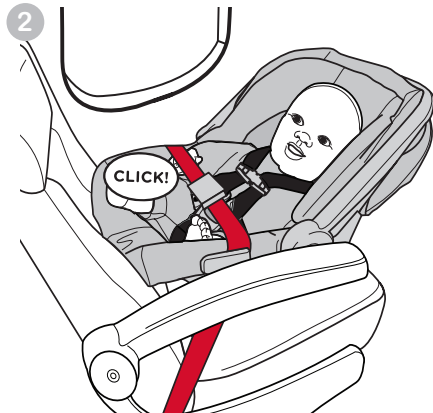

- 3 Push infant carrier firmly back and down towards the aircraft seat as you tension the belt by pulling on the free end of the lap belt strap. If necessary, tuck the loose end of the lap belt out of the way.

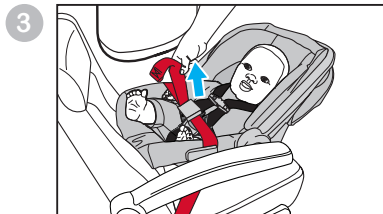



USING THE INFANT CARRIER ON AN AIRCRAFT

- 4 Grab the infant carrier at the belt guides and pull from side to side and front to back to make sure it is installed correctly. The infant carrier should not move more than 1 inch (2.5 cm) in any direction. If the infant carrier moves too much, tighten the aircraft belts more and re-check.

Check the recline angle. Adjust the seat angle until the red level line on the infant carrier is level with the floor of the aircraft. A tightly rolled airline blanket may be placed under the infant carrier to adjust the angle. See pg. 79.

- 5 ALWAYS place handle in Position 1 or 2 on an aircraft. DO NOT use any other handle position.

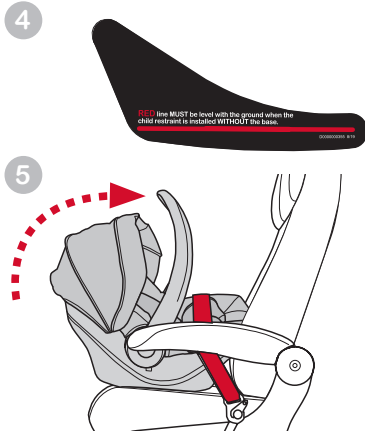



USING THE INFANT CARRIER ON AN AIRCRAFT

- 6 To remove, unfasten aircraft belt. Always place handle in POSITION 2 before carrying.

DO NOT USE THE BASE ON AN AIRCRAFT. IT IS NOT CERTIFIED FOR USE ON AIRCRAFT. If you plan to use the base at your destination, don't forget to check it at the gate or check it in as luggage.

CONTACT THE AIRLINES AHEAD OF TIME FOR ANY SPECIFIC POLICIES OR QUESTIONS.

Este asiento de seguridad para niños debe estar bien sujeto al asiento del avión en todo momento, incluso cuando esté desocupado. Un sistema de retención infantil sin garantía puede lesionar a alguien si ocurre un turbulencia.

LATCH STORAGE

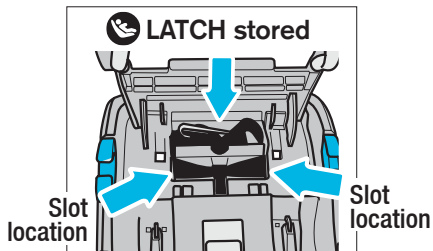

When storing, place the **LATCH** strap and hooks inside the **LATCH** storage.

Insert the straps on either side of the storage area in the designated slots.

NEVER allow straps to lie outside the storage area when **LATCH** is not in use as it may interfere with the carrier latching to the base.

INSTRUCTION MANUAL STORAGE

THERE ARE TWO LOCATIONS FOR MANUAL STORAGE:

BASE:

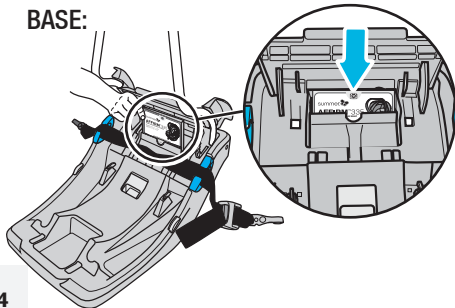

CARRIER:

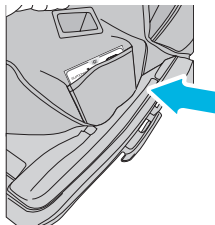

There is a pocket underneath the seat pad. LOOK for the location near the book icon on the front of seat pad.



CARE AND MAINTENANCE

⚠ WARNING

NEVER USE THE INFANT CAR SEAT WITHOUT THE SEAT PAD INSTALLED.

DO NOT damage, remove or dispose of any EPS foam.

NEVER twist or cross the shoulder straps or place them in the incorrect level slots.

Removing the Infant Body Insert

- 1 Turn carrier over and unfasten the infant body insert strap from the back of the seat shell.
- 2 Slide shoulder harness straps out from the infant body insert slots.

If your harness is in the lowest set of infant body insert slots you will need to do steps 4 and 5 on the next page in order to remove the harness straps from the insert.

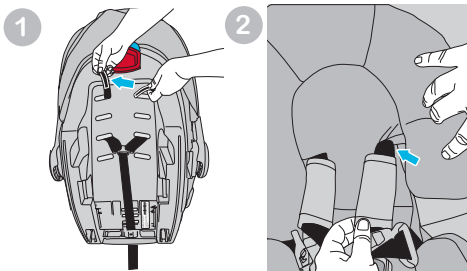

CARE AND MAINTENANCE

- 3 Push the buckle down through the body insert and the seat pad.

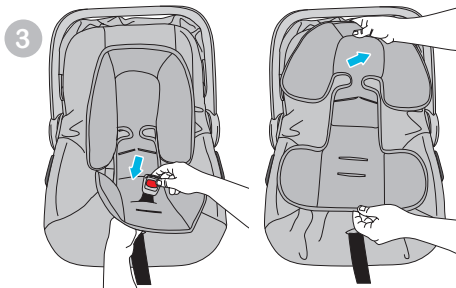

- 4 Turn seat over and remove the harness straps from the harness splitter plate.

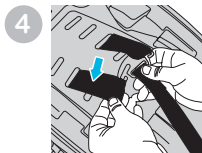

- 5 Pull harness straps out through the front of the seat shell and seat pad.

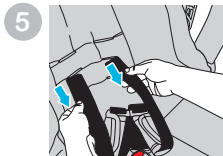

- 6 Remove the harness covers.

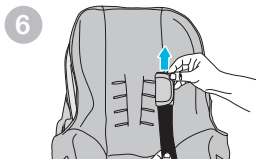

CARE AND MAINTENANCE

- 7 Lift the canopy mount tab on each side of seat and pull canopy out from the side of the seat.

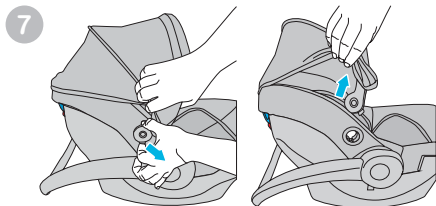

- 8 Unfasten the plastic tabs all around the seat pad.

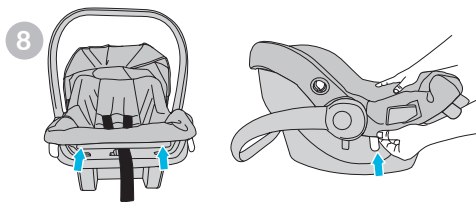

CARE AND MAINTENANCE

- 9 Pull seat pad towards front of seat and peel seat pad off both vehicle belt guides on the sides of the seat.

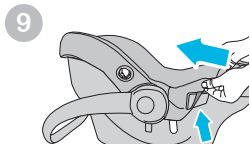

- 10 Pull the plastic tab out below the canopy mount hole.

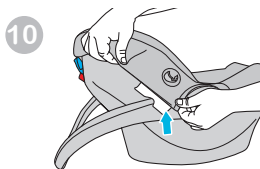

- 11 Pull the plastic tab out from the rear of the seat above the shoulder belt guide.

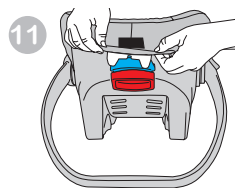

- 12 Push the buckle tongue and chest clip through the waist slots on the seat pad.

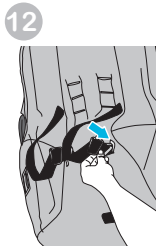

- 13 Push the buckle down through the seat pad slot.

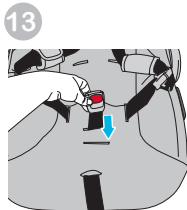

- 14 Remove seat pad off of the shell.

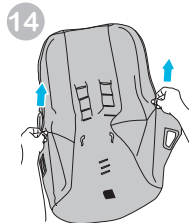

CARE AND MAINTENANCE

Re-attaching the Seat Pad, Harness Covers and Infant Body Insert

1. Lay pad in seat, thread harness straps, chest clips and buckle tongue through the waist strap slots. (If you need to use the lowest slots for the infant body insert, place insert into seat and thread harness straps through the lowest infant insert slots.)
2. Insert crotch buckle through desired crotch slot position on seat pad.
3. Insert shoulder straps into respective slots for your size child.
4. Turn seat over and attach shoulder straps onto desired loops onto the harness splitter plate.
5. Wrap seat pad around vehicle belt guide on both sides of seat.
6. Working from the front of the seat, wrap seat pad around the edge so the tab snaps under the front edge of seat.
7. Pull harness adjuster strap through slot on seat pad.
8. Wrap the tabs on seat sides until they are inserted into place.
9. Wrap tab on rear of seat, tuck law tag under seat pad.
10. Attach harness covers to shoulder straps above chest clip.
11. Re-attach canopy, pull on canopy mount to make sure that it is attached.
12. Insert body support, then insert crotch strap through the appropriate slots for child's size.
13. Re-insert infant body insert strap through the top slots on seat pad and through the seat shell and secure back onto themselves.

CARE AND MAINTENANCE

Harness Buckle

Food, drink or other debris may collect inside the harness buckle which can affect proper function.

Suspend the buckle in warm water and shake it back and forth. Push the button several times to make sure the buckle is working properly.

DO NOT use child restraint if buckle tongues ***DO NOT*** click into the buckle. Try cleaning the buckle. If this does not remedy the problem, please call Customer Service 1-401-671-6551 before using the child restraint.

Do not use detergents or lubricants.



CARE AND MAINTENANCE

Harness Straps

Sponge clean using warm water and mild soap. Air dry. Do not iron.

Plastic Parts

All plastic parts except the buckle can be cleaned with a mild detergent and warm water.

Spot Cleaning

Spot clean seat pad, harness covers, and the infant body insert as needed with a clean cloth using mild detergent and water.

NEVER IMMERSE THE LATCH OR HARNESS STRAPS.

Seat pad, infant body insert and harness covers;

- Machine wash **COLD**, delicate cycle, mild detergent
- Drip Dry

To avoid seat cover parts shrinking:

- **DO NOT** machine wash warm or hot
- **DO NOT TUMBLE DRY**
- **DO NOT** iron
- **DO NOT** use bleach

CUSTOMER SUPPORT, WARRANTY AND REPLACEMENT PARTS

For customer support, warranty and replacement parts information, please contact:

Summer Infant (USA) Inc.

1275 Park East Drive
Woonsocket, RI 02895
or call 1-401-671-6551

For install instructions, scan the QR code with your camera or QR reader. If you have any questions or need further assistance, contact our Consumer Relations Team at 401-671-6551 or visit www.summerinfant.com/contact

