



GOODBABY

**EVENFLO EVERYFIT
EVENFLO EVERYKID****Type:** Convertible/Combination**Last date made:** Current**First made:** 2019**Weight limits:** 4 to 40 lbs. rear-facing, 22 to 65 lbs. and at least two years old forward facing with harness. 40 to 120 lbs. and at least four years old when used as belt-positioning booster with vehicle lap and shoulder belt on child (harness removed).**Harness:** 5-point harness

Harness: Harness is threaded through slots at shoulders to a height adjuster in shell; they are not accessible from rear of seat. Pull strap end in front of seat to tighten harness. Press button at lower front of seat and pull harness straps to loosen. Use of harness strap covers is optional.

Harness slots: There is one set of slots, which may be raised or lowered to one of twelve positions by grasping handle at top of seat (diagram 1), then moving harness upward or downward. Make sure harness is locked into position after adjusting.

Crotch strap: There are two positions. Crotch buckle must be in inner slot for rear-facing installations, and for forward-facing installations with child under 30 lbs. Outer slot must be used for forward-facing installation for child weighing 30 lbs. or more. To change crotch buckle position, remove seat back from base (see Other section), turn metal anchor sideways, feed anchor through slot, and re-thread into desired slot.

Angle adjustment: Rear facing—Lift up recline lever at lower front of seat and adjust to one of three positions. When rear-facing, the level line on the sticker on the side of the seat must be parallel to the ground (diagram 2). Use of a rolled towel or small blanket in the seat bight is permitted to achieve proper angle when recline adjuster is not in use. When installed forward-facing with harness or in booster mode, the seat must be in the most upright position.

Belt path: If LATCH is not in use, store connectors on storage location on the side of restraint (diagram 3). If installing rear-facing, route LATCH strap through forward facing belt path, if installing forward-facing, route LATCH strap through rear-facing belt path. **Do not install using inflatable safety belt.**

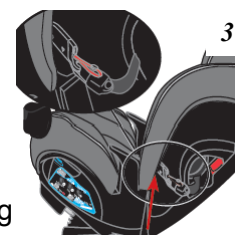
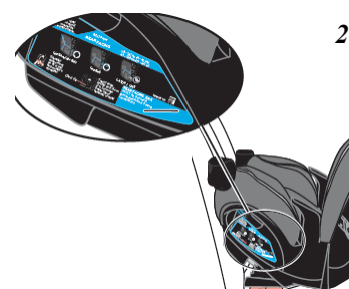
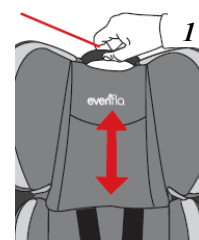

SEE PAGE 2

Belt path: (cont.)

Rear-facing: Pull cover off front of restraint, route vehicle belt through rear-facing belt path in front of the crotch strap (diagram 4) and buckle. Reconnect seat pad, tighten belt, insert shoulder belt in lock-off on the side of the restraint opposite of seat belt buckle (diagram 5), and, if vehicle permits, lock retractor. Do not use lockoff with lap-only belt.

Forward-facing: Raise headrest to highest position and lift up headrest pad to access belt path. Route vehicle belt through forward-facing belt path, buckle, and tighten, then insert shoulder belt into forward-facing lock-off on the side of restraint opposite of seat belt buckle (diagram 6). If vehicle permits, lock retractor. Do not use lockoff with lap-only belt.

Without harness: .Extend harness straps completely, unfasten chest clip and crotch buckle. Remove seat base from booster back (see Backrest section) to access and remove crotch buckle. Reattach seat base and store crotch buckle by inserting anchor into slot at rear of seat base (diagram 7). To store harness, lift up headrest pad and disconnect hook and loop connectors on seat pad (diagram 8). Push shoulder straps behind headrest pad, then pull harness straps, chest clip, and buckle tongues through forward-facing belt path (diagram 9). Raise or lower headrest to desired height, then close chest clip behind the seat. Replace headrest pad. Use vehicle lap-shoulder belt on child and thread shoulder belt through belt guide (diagram 10). Seat must be in upright position.

Backrest: Removable. Make sure lower connector strap is in forward-facing belt path. To convert to backless booster, lay restraint on its back and lift up panel in seat pad to access release handle (diagram 11). Lift up and hold release handle while lifting booster base off seat back (diagram 12). If crotch buckle is still attached, remove and store on seat back (diagram 7). An adjustable shoulder belt positioner strap is provided if needed to properly position shoulder belt. Feed looped end of shoulder belt adjuster through slot on back of booster (diagram 13), then feed clip and strap through loop. Place clip on vehicle shoulder belt just above child's shoulder. Adjust length of strap until vehicle shoulder belt is centered on child's shoulder and chest.

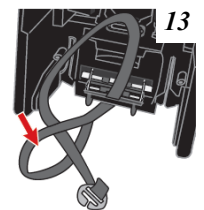
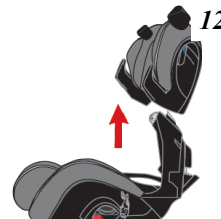
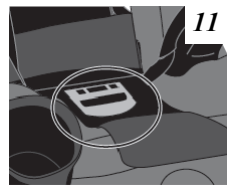
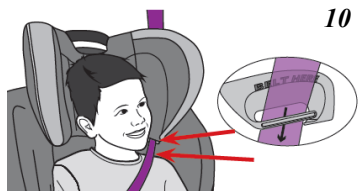
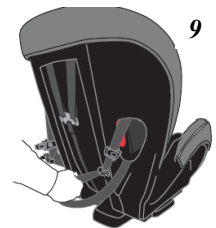
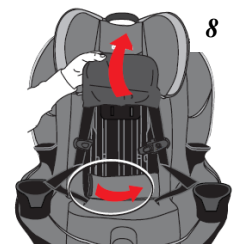
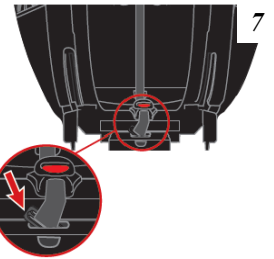
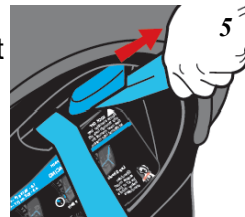
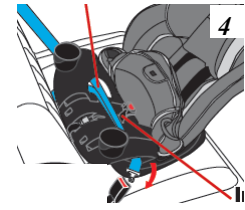

SEE PAGE 3

LATCH: Models are equipped with either EasyClick Connectors or Quick Connectors (diagram 14). If restraint is equipped with EasyClick Connectors, position strap through appropriate belt path, connect to anchors, and tighten by moving adjustment mechanism down and rotating (diagram 8) until installation is secure. If restraint is equipped with Quick Connectors, make sure connectors face upward. Thread LATCH connectors through correct belt path, connect to anchors, and tighten adjustment strap. If installing rear facing, and crotch strap is in inner slot, make sure LATCH strap is in front of crotch strap. If installing rear facing and crotch strap is in outer slot, make sure LATCH strap is behind crotch strap. Discontinue use of lower anchors at 40 lbs. regardless of orientation of restraint. LATCH may be used in center seating position when permitted by vehicle manufacturer and spacing is 11-20 inches. When moving LATCH straps from one belt path to the other, be sure strap is flat before installing restraint. You may need to twist strap to accomplish this. Lower anchors and tether may be used in booster mode as long as belt fit is correct on child and adjacent safety belts are not affected.

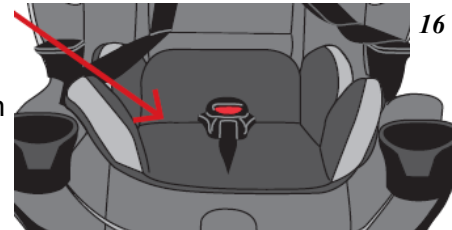
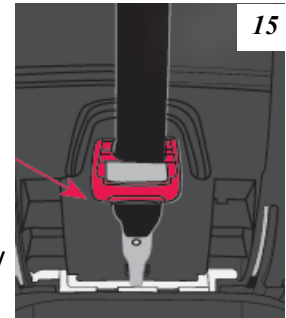
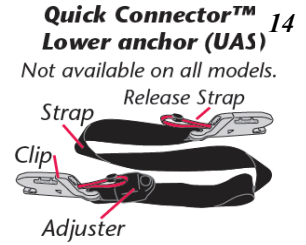
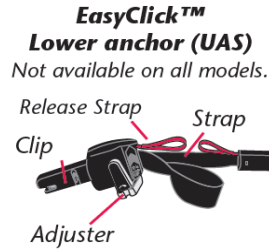

Tether: Yes, must be used forward-facing in harness mode, optional in booster mode. Clip to back of restraint when not in use (diagram 15).

Your head pillow may be one of two different styles. 17 install:

Other: Use body pillow (diagram 16) and infant head support (diagram 17) only in rear-facing mode.

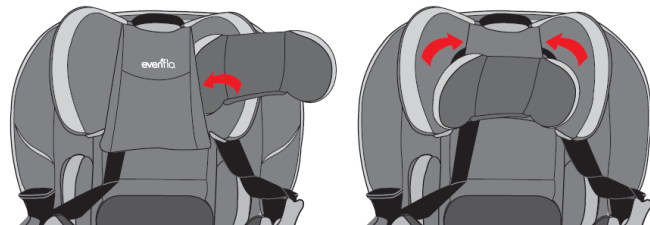

Cup holders **MUST** be used in rear-facing mode.

Any Evenflo child restraint may be used adjacent to a side airbag, provided that the vehicle manufacturer designates that location as an appropriate child restraint seating position.

Restraint expires ten years from date of manufacture.



EveryFit

4-in-1 Car Seat Owner's Manual

Keep instructions for future use.

REAR-FACING*

1.8 - 18.1 kg
(4 - 40 lbs)

43 - 102 cm
(17 - 40 in.)

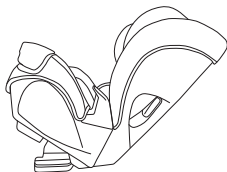

FORWARD-FACING WITH HARNESS*

10 - 29.5 kg
(22 - 65 lbs)

71 - 124 cm
(28 - 49 in.)

At least 2 years old

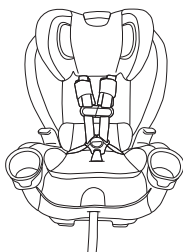

HIGH-BACK OR BACKLESS BOOSTER*

18 - 54.4 kg
(40 - 120 lbs)

112 - 145 cm
(44 - 57 in.)

At least 4 years old

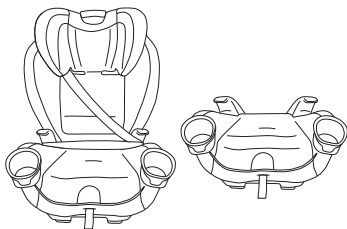

* See "Child Requirements" on pages 4 - 5.

Para instrucciones en Español,
llamar al: 1-800-233-5921

WARNING!

To reduce the risk of serious injury or death, read this owner's manual prior to installing and using this child restraint.

More children are killed every year as passengers in car crashes than by any other type of injury.

To reduce the risk of **SERIOUS INJURY** or **DEATH**, read this owner's manual and your vehicle owner's manual before installing and using this child restraint. Using a child restraint makes a big difference. By properly using this child restraint and following these instructions (and the instructions that accompany your vehicle), you will greatly reduce the risk of serious injury or death to your child from a crash. Do not be misled by the commonly used term "safety seat"; no restraint system can prevent all injuries in all crashes. Many properly restrained adults and children are injured in motor vehicle crashes, including relatively minor crashes. A properly used child restraint is the best way to minimize injuries to your child and to increase the chances for survival in most crashes.

FEDERAL STANDARD NO. FMVSS213 - Child Restraint Systems

This child restraint conforms to all applicable Federal motor vehicle safety standards.

CANADIAN REGULATORY NOTICE (Model numbers ending in "C.")

This child restraint meets all applicable requirements of Canadian Motor Vehicle Safety Standards CMVSS 213, 213.1, and 213.2.

Symbol Legend



Airbag Symbol – Alerts you to important information about airbag safety.



LATCH Symbol – Alerts you to important information about LATCH safety.



Tether Anchor Symbol – Alerts you to important information about Tether Anchor safety.



Aircraft Symbol – Alerts you to important information about aircraft safety.

Table of Contents

Important Information

Child Requirements	4
Premature Infant Use	6
Warnings	7
Safe Practices	18
Recall Information for U.S. Customers	18
Public Notice for Canadian Customers	19
Motor Vehicle/Aircraft Usage	19
Child Restraint Features	20

Important

Rear-facing

Using the Child Restraint Rear-facing	26
Rear-facing Installation with Lower Anchor (UAS) Connectors	27
Rear-facing Installation with Vehicle Seat Belts	33
Rear-facing Installation Checklist	37

Rear-facing

Forward-facing with Harness

Using the Child Restraint Forward-facing with Harness	38
Forward-facing Installation with Lower Anchor (UAS) Connectors	39
Forward-facing Installation with Vehicle Seat Belts	46
Forward-facing Installation Checklist	52

Forward-facing

Booster Mode

Using the Child Restraint as a Booster Seat	53
Using Your Booster Seat in High-Back Mode	55
High-Back Booster Installation Checklist	58
Using Your Booster Seat in Backless Booster Mode	59
Backless Booster Installation Checklist	62

Booster

General Information

Reattaching the Booster Back	63
Reattaching Booster Back	64
Adjusting the Headrest/Harness Position	65
Reclining Child Restraint	66
Adjusting the Crotch Buckle Position	67
Securing the Child in the Child Restraint	68
Removing the Child from the Child Restraint	70
Removing the Tether Strap	71
Installing Child Restraint Rear-facing in Aircraft	72
Installing Child Restraint Forward-facing in Aircraft	74
Removing the Seat Cover	76
Reattaching the Seat Cover	79
Care and Cleaning	81
Recording Model Information	82
Storing Your Instructions	82
Proper Disposal	82
Replacement Parts	83
Limited Warranty	84

General

Child Requirements

⚠️WARNING

Failure to follow these Child Requirements could result in serious injury or death.

This child restraint is designed for use by children in both **rear-facing** and **forward-facing** orientations. To use this child restraint properly, children **MUST** meet the size and age requirements below. In addition, Evenflo recommends consulting with your child's physician before allowing your child to transition from **rear-facing** to **forward-facing** use of this child restraint.

The American Academy of Pediatrics (AAP) recommends keeping children **rear-facing** for as long as possible, until they reach the maximum height or weight for their child restraint in **rear-facing** orientation. Additionally, some states' laws require children to be **rear-facing** until age 2. Accordingly, you will see this guidance reflected in the Child Requirements below. Please review any applicable local, state or provincial laws related to child passenger safety before installing and using this child restraint.

Rear-facing

- 1.8 - 18.1 kg
(4 - 40 lbs)
- 43 - 102 cm
(17 - 40 in.)
- Top of child's head is at least 2.5 cm (1 in.) or more below the top of the child restraint headrest



IMPORTANT: Once your child exceeds any of the size requirements above, they **MUST** use this child restraint in the forward-facing orientation, if possible. If your child exceeds any of the size requirements above **and** is less than 2 years old, however, you **MUST** discontinue use of this child restraint.

Child Requirements

Forward-facing with Harness

- 10 - 29.5 kg
(22 - 65 lbs)
- 71 - 124 cm
(28 - 49 in.)
- Tops of the child's ears are at or below the top of the child restraint headrest
- At least 2 years old



Important

IMPORTANT: Once your child **exceeds** any of the size requirements for **forward-facing** use above, you **MUST** discontinue use of this child restraint with its internal harness and begin using it in booster mode, if possible. If your child **exceeds** any of the size requirements for **forward-facing** use above **and** is less than 4 years old, however, you **MUST** discontinue use of this child restraint.

Booster Mode

- 18 - 54.4 kg
(40 - 120 lbs)
- 112 - 145 cm
(44 - 57 in.)
- Tops of the child's ears are at or below the top of the booster seat headrest (high-back mode) or vehicle seat headrest (backless mode)
- At least 4 years old



IMPORTANT: Once your child **exceeds** any of the size requirements above for **booster mode**, you **MUST** discontinue use of this seat. Your child may be ready for use of the vehicle belt system only at this time.



Premature Infant Use

Before using this child restraint for preterm or low birth weight infants, ensure the Child Requirements are met and follow the guidelines in this section.

According to the U.S. National Highway Traffic Safety Administration, a properly installed child restraint reduces the risk of death by over 70 percent for infants involved in crashes. Federal Motor Vehicle Safety Standard (FMVSS) 213 establishes design and dynamic performance requirements for child restraint systems. However, the standard has no minimum weight limit and does not address the special medical needs of preterm or low-birth weight infants. To ensure that preterm and low-birth weight infants are transported safely, the guidelines published by the American Academy of Pediatrics (AAP) in Pediatrics 2009; 123:1424–1429 must be followed.

All children should ride rear-facing in the vehicle as long as possible. Preterm and low-birth weight infants are at additional risk of breathing difficulties and heart problems when placed in a child restraint. Evenflo requires that the evaluation recommended by the AAP be conducted for all infants born earlier than 37 weeks and all newborn infants who weigh less than 2.26 kg (5 pounds) at birth before their first car trip to check for breathing difficulties or heart rate problems when traveling in a rear-facing child restraint.

The AAP recommends that appropriate hospital staff observe your infant in the child restraint for a period of 90 - 120 minutes or the duration of travel, whichever is longer. This period of observation must be performed with the infant properly positioned as described in these instructions and with the child restraint placed at an angle that is approved for use in the vehicle. The hospital staff will check for any breathing difficulties or heart rate problems. Your child's pediatrician will let you know if there are any special considerations for travel. The number of trips and the duration of time the infant is seated in the child restraint should be minimized. A caregiver should ride in the back seat to monitor the infant during travel.

You can learn more about the AAP's recommendations for observation of newborns and the guidelines for safe transportation of preterm and low-birth weight infants, as well as other resources for parents and medical professionals, at

<https://www.healthychildren.org/english/safety-prevention/on-the-go/Pages/default.aspx>

⚠ WARNING! DEATH or SERIOUS INJURY can occur.

Airbag Warnings



Important

⚠ WARNING / MISE EN GARDE



DO NOT place rear-facing child seat on front seat with air bag.

DEATH OR SERIOUS INJURY CAN OCCUR. The back seat is the safest place for children 12 and under.

NE PAS placer un dispositif de retenue pour enfant en orientation face à l'arrière sur un siège avant doté d'un sac gonflable.

RISQUE DE DÉCÈS OU DE GRAVES BLESSURES. Le siège arrière offre le plus de sécurité pour les enfants âgés de 12 ans ou moins.

- **DO NOT** use this child restraint in the front seat of a vehicle equipped with an air bag, unless the air bag has been deactivated. Interaction between a rear-facing restraint and air bags may cause serious injury or death. Air bags may cause serious injury or death to children 12 years of age and under. If your vehicle has an air bag, refer to your vehicle owner's manual for child restraint installation.
- **DO NOT** place any objects between the restraint and the side air bag, as an expanding air bag may cause the items to strike your child.
- If the rear seat of your vehicle is equipped with side air bags, refer to the following information for proper usage:

Vehicles built prior to the 2002 model year:

DO NOT use this restraint in a vehicle seating position equipped with a side air bag unless authorized by the vehicle manufacturer.

Model year 2002 and newer vehicles:

Refer to your vehicle owner's manual before placing this restraint in a seating position equipped with a side air bag.

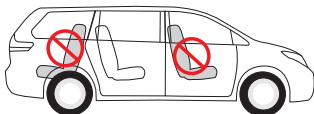
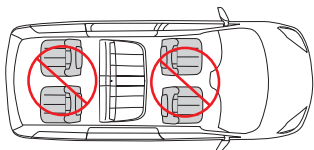

The forward facing back seat is the safest place for children 12 and under.

⚠ WARNING! DEATH or SERIOUS INJURY can occur.

General Warnings

- Failure to follow the Child Usage Requirements for **rear-facing, forward-facing** and **booster mode** for this child restraint could result in serious injury or death. (See "Child Requirements" on pages 4 - 5).
- Failure to follow installation instructions and the instructions and warning labels on product can result in the child striking the vehicle's interior during a sudden stop or crash. Serious injury or death may result. These instructions and the instructions in your vehicle owner's manual must be followed carefully. If there is a conflict between the two, the vehicle owner's manual regarding child restraint installation must be followed.

⚠ WARNING/MISE EN GARDE

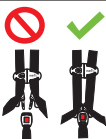

Children have **STRANGLLED** in loose or partially buckled harness straps. Fully restrain the child even when carrier is used outside the vehicle.

Des enfants se sont **ÉTRANGLÉS** dans des sangles de harnais desserrées ou mal serrées. Attacher complètement l'enfant même lorsque le porte-bébé est utilisé hors du véhicule.

- **NEVER** leave child unattended.
- **DO NOT** use child restraint if it is damaged, broken, or missing parts.
- **DO NOT** use this restraint if it has been involved in a crash. It must be replaced.

⚠️ WARNING! DEATH or SERIOUS INJURY can occur.

Location Warnings

Important

- **ALWAYS** read and follow exactly the instructions that accompany your vehicle and child restraint.
- According to accident statistics, children are safer when properly restrained in the rear seating positions than in the front seating positions. Generally, the center rear position is safest and should be used if available.
- Some child restraints do not fit all vehicles or all seating locations. There are many thousands of combinations of vehicle makes, models, child restraint configurations, vehicle seat belt designs, and seat cushion shapes. The easiest way to determine whether your child restraint is suitable for a particular seating position is to check for a tight installation. If the child restraint cannot be properly installed, **DO NOT** use the child restraint. Consult vehicle owner's manual, try a different seating location, or call Evenflo for further assistance.
- **ONLY** use this child restraint on **forward-facing vehicle seats**. **DO NOT** use this restraint with vehicle seats that face the rear or side.

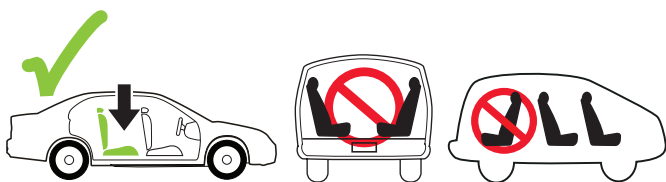

- **ONLY** use this child restraint on vehicle seats with backs that lock into place.
- **VEHICLE TYPES IN WHICH THE RESTRAINT SYSTEM CANNOT BE USED:**
This child restraint is not to be used in vehicles that do not have vehicle seat belts or UAS lower anchorages.

⚠️ WARNING! DEATH or SERIOUS INJURY can occur.

Rear-Facing Warnings

- When using this restraint rear-facing, **DO NOT** loosen the vehicle seat belt to provide more leg room, as this may keep the child restraint from protecting your child.
- Fold-down armrests could pose a hazard to a rear-facing child in certain types of collisions. Consult your vehicle owner's manual before installing any rear-facing child restraint in front of a fold-down armrest.
- **DO NOT** use the tether strap when the child restraint is installed rear-facing.
- The headrest on the vehicle seat that the child faces when sitting rear-facing should be placed in the lowest position. The vehicle seat back that the child faces must be fully padded and free of any hard objects.
- Cup holders **MUST** remain attached to the restraint **AT ALL TIMES** in rear-facing mode.
- **IMPORTANT:** Infants may have difficulty breathing when in an upright seated position. Make sure they recline enough for their head to lie back comfortably and safely. Failure to properly recline the child restraint could increase the child's risk of serious injury or death.

Forward-Facing Warnings

- **Adjust or remove the vehicle headrest in the seat where the child restraint is to be installed,** so the back of the child restraint rests against the vehicle seat back.
- The headrest on the vehicle seat in front of the child should be put in its lowest position. The vehicle seat back that the child faces must be fully padded and free of any hard objects.

! WARNING! DEATH or SERIOUS INJURY can occur.

Booster Mode Warnings

Important

- **DO NOT** use this booster seat rear-facing.
- Use **ONLY** the vehicle's lap **AND** shoulder belt system when restraining the child in this booster seat. **Never use a booster with only a lap belt**, as this could cause serious injuries.
- The shoulder belt **MUST** cross midway between the child's shoulder and neck.
 - **In high-back booster mode**, thread shoulder belt through the shoulder belt guide.
 - **In backless booster mode**, thread shoulder belt through the shoulder belt clip if needed. (See "Using the Shoulder Belt Clip" on pg. 61.)
- **DO NOT** use this booster seat if the tops of the child's ears are above:
 - **In high-back booster mode**, the top of the booster seat headrest
 - **In backless booster mode**, the top of the vehicle headrest.
- The shoulder belt **MUST NOT** cross the child's neck **or** fall off the child's shoulder. If you cannot adjust the shoulder belt to properly lay midway between the child's shoulder and neck **AND** at or above the shoulder, try another seating location or do not use the booster seat.
- **IMPORTANT:** Always secure the booster seat with the vehicle seat belt or lower anchors when not occupied. An unsecured booster seat can fly into and injure other occupants in the event of a crash.



⚠ WARNING! DEATH or SERIOUS INJURY can occur.

Seat Belt Warnings

- **ALWAYS** read your vehicle owner's manual to determine what vehicle belts and retractors are used in your vehicle.

Lock your retractors if available in your vehicle.

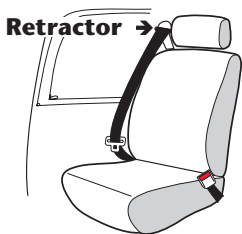

- **DO NOT** use this child restraint if it moves more than 2.5 cm (1 in.) side to side or front to back at the belt path in use. Serious injury or death may result from loose installation. If you cannot tightly secure the child restraint, try again or move it to another location.

- **DO NOT** use this child restraint in a seating position with door-mounted seat belts.



- **DO NOT** use this child restraint in a vehicle with seat belts that automatically move along the vehicle frame when the door is opened.



- **DO NOT** use this child restraint in a vehicle equipped with lap belts that only lock during a sudden stop or crash (Emergency Locking Retractor – ELR). You must use a seating location with a lap/shoulder belt or a locking lap belt. Check your vehicle owner's manual to see if you have lap belts with ELRs.



- **DO NOT** use on vehicle seats when both portions of the vehicle belts are positioned forward of the seat crease.



⚠️ WARNING! DEATH or SERIOUS INJURY can occur.

Seat Belt Warnings

- **DO NOT** use with lap/shoulder belts with two retractors. If the vehicle seat belts are not routed and fastened correctly, the child restraint may not protect the child in a crash.



Important

- **DO NOT** use with inflatable seat belts.
- Check your vehicle owner's manual to determine how to lock your seat belt for child restraint installation.
- **DO NOT** allow the vehicle seat belt release button to touch the child restraint. Accidental contact may cause the seat belt to release. If necessary, turn the seat belt release button away from the child restraint or move the child restraint to a different location.
- Failure to adjust the harness or vehicle seat belts snugly around the child may result in the child striking the vehicle's interior during a sudden stop or crash. Serious injury or death may occur.
- This child restraint must be securely belted to the vehicle, **even when it is unoccupied**, since in a crash an unsecured child restraint system may injure other occupants.

⚠️ WARNING! DEATH or SERIOUS INJURY can occur.

Seat Belt Warnings

If you have any of these types of vehicle belt systems listed, these are SAFE to use to install your child restraint in the vehicle. Review vehicle owner's manual for specific instructions on child restraint installation.

LATCH can be used IN PLACE OF these vehicle belt types. Refer to the Rear-facing and Forward-facing weight limits on **LATCH** use on pages 28 and 40. Refer to your vehicle owner's manual for **LATCH** locations.

Lap Belt with Locking Latch Plate

Once buckled, the vehicle belt is tightened by pulling on the free end of the strap until the belt is tight.

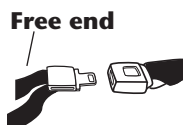

Lap Belt with Automatic Locking Retractor (ALR)

The automatic locking retractor does not allow the lap belt to get longer once it is buckled. The vehicle belt is tightened by feeding seat belt webbing into retractor.

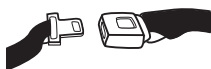

Lap/Shoulder Belt with Locking Latch Plate

The lap portion of this belt does not loosen once the belt is buckled.

The vehicle belt is tightened by pulling up hard on shoulder belt and feeding the extra webbing into the retractor.

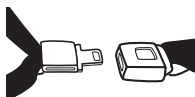

Lap/Shoulder Belt with Sliding Latch Plate with Locking Retractor

The latch plate slides freely along the lap/shoulder belt. Vehicle belts with sliding latch plates are typically locked at the shoulder belt retractor by buckling the belt and pulling all of the webbing out slowly to switch the retractor.

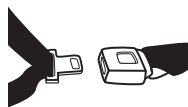

Check vehicle owner's manual for specific instructions. The vehicle belt is tightened after switching the retractor by pulling up on shoulder belt and feeding the webbing into the retractor.

⚠️ WARNING! DEATH or SERIOUS INJURY can occur.

LATCH/UAS Warnings



Important

What is **LATCH**?

LATCH is an acronym for (**L**ower **A**nchors and **T**ethers for **C**hildren) and refers to a pair of fixed Lower Anchors (or bars) and a Top Tether anchor that are built into your vehicle, in vehicles built after September 1, 2002.

The lower **LATCH** anchors are located in the crease, or bight, between the vehicle seat back and seat cushion, and if not visible, will typically be indicated by the  symbol. Top tether anchors are located in various places behind the rear vehicle seat.

Vehicle Top Tether Anchor Points

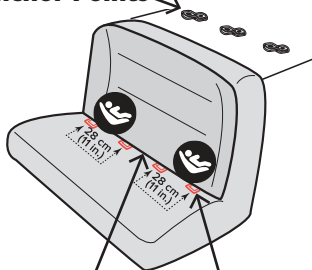

Vehicle Seat Crease

Vehicle Lower Anchors

Center installation in a non-standard LATCH position:

Center installation of this child restraint is permitted using inner Lower Anchor Bars from the outside seating positions if:

1. your vehicle manual allows such installation; and
2. the inner Lower Anchor Bars from the outside seating positions are 28 - 51 cm (11 - 20 in.) apart.

LATCH typically offers an easier and more consistent installation. However, this child restraint can be safely installed using either **LATCH** or vehicle belts and meets the requirements of Federal Safety Standard FMVSS 213 with either installation method. Either method is safe for your child when installed correctly. When using either method, it is best practice to **ALWAYS USE** tether when installing in the forward-facing position.

DO NOT install this child restraint with **LATCH** and the vehicle's seat belts at the same time. Your vehicle owner's manual may refer to this system as **ISOFIX**, **Universal Anchorage System (UAS)**, or **Lower Universal Anchorage System**.

The **LATCH** system is intended to be used **ONLY** as described in these instructions. Serious injury or death may result from misuse. Refer to your vehicle Owner's Manual for lower anchor bar positions in your vehicle.

WARNING! DEATH or SERIOUS INJURY can occur.



LATCH/UAS Warnings

- **DO NOT** use the lower anchors of the child restraint anchorage system (**LATCH** system) to attach this child restraint when restraining a child weighing more than 18 kg (40 lbs) with the internal harnesses of the child restraint. **ONLY USE VEHICLE BELT INSTALLATION.**
- In addition to these instructions, read and follow your vehicle owner's manual regarding installation of the child restraint and **LATCH**. If there is a discrepancy, follow your vehicle owner's manual.
- **ONLY** use for securing child restraint to vehicle lower anchor bars.
- **NEVER** attach two lower anchor connectors to one vehicle lower anchor bar.
- **NEVER** use the vehicle seat belts when using the lower anchor connector assembly. Using both together can cause slack in a sudden stop or crash.
- To avoid strangulation, you must store the unused **LATCH** straps, with all slack removed, in the storage areas on the sides of your seat. Roll or fold the excess **LATCH** strap and secure with a rubber band to prevent serious injury to vehicle occupants.
- **ALWAYS** be sure that the lower anchor connectors are attached to the vehicle lower anchor bars by pulling hard on the lower anchor connectors. If they are not attached, the lower anchor connector assembly will not secure your child restraint. Serious injury or death may result.
- **DO NOT** use this child restraint if it moves more than 2.5 cm (1 in.) side to side or front to back at the belt path in use. Serious injury or death may result from poor installation. If you cannot tightly secure the child restraint, try again or move it to another location.

⚠️ WARNING! DEATH or SERIOUS INJURY can occur.

Tether Strap Warnings



Important

- To avoid a strangulation hazard, you **MUST** tightly roll or fold excess of unused tether strap and secure with a rubber band. Attach the tether hook to the storage clip when not in use. (See "Removing the Tether Strap on pg. 71). This will keep an unused tether or tether hook from hitting someone during a crash.

Additional Warnings

- **DO NOT** use the cup holder to store cans or hard cups. **DO NOT** place any cups that contain hot liquids in the cup holder.
- **DO NOT** attach additional padding, toys, or other devices not made by Evenflo or described in these instructions for the child restraint. Items not tested with the child restraint could injure the child. Additional pads or pillows may interfere with the function of the harness system, or cause breathing problems if the child's head falls forward, increasing the risk of serious injury or death.
- In hot or sunny weather, **ALWAYS** check the areas of the child restraint that may contact your child (e.g., buckle, buckle tongues, etc.) for hot areas before placing him/her into the child restraint. The child could be burned. Cover the child restraint with a light colored blanket when you leave the vehicle.
- In cold weather, **DO NOT** dress the child in bulky clothing like snowsuits if the child is riding in a child restraint. Bulky coats/snowsuits make it difficult to properly tighten the harness to the child, which may allow the child to be ejected from the restraint during a crash. If necessary, place a blanket over the harnessed child without interfering with the child restraint harness system.

Safe Practices

- **Everyone rides buckled up or the vehicle does not go.** Make no exceptions for adults or children. If someone unbuckles, stop the vehicle. Being firm and consistent from the start will mean fewer discipline problems as children get older. An unrestrained person can be thrown into and injure other passengers.
- **NEVER** try to tend to a crying baby's needs while driving. **NEVER** take a baby out of a child restraint for comforting while the vehicle is moving.
- **DO NOT** allow a child in a vehicle to have objects such as lollipops or ice cream on a stick. The object can injure the child if the vehicle swerves or hits a bump.
- **DO NOT** feed an infant who is riding in a child restraint.
- Put sharp or heavy items in the trunk. Anything loose can be deadly in a crash.

Recall Information for U.S. Customers

- Child restraints could be recalled for safety reasons. You must register this restraint to be reached in a recall. Send your name, address, email address if available, and the restraint's model number and manufacturing date to:

Evenflo Company, Inc.

1801 Commerce Dr.

Piqua, OH 45356

or call 1-800-233-5921

or register online at

www.evenflo.com/registercarseat

- For recall information, call the U.S. Government's Vehicle Safety Hotline at 1-888-327-4236 (TTY:1-800-424-9153), or go to <http://www.NHTSA.gov>

Tear off and mail this part

Consumer: Just fill in your name and address and e-mail address.

Your Name _____

Your Street Address _____

City _____

State _____

Zip Code _____

E-mail Address _____

CHILD RESTRAINT REGISTRATION CARD

Public Notice for Canadian Customers

- Child restraints could be recalled for safety reasons. You must register this restraint to be reached in a recall. Send your name, address, and the restraint's model number and manufacturing date to:

Evenflo Company, Inc.
1801 Commerce Dr.
Piqua, OH 45356

or call 1-937-773-3971

or register online at:

www.evenflo.com/registercarseatcanada

- For public notice information, call Transport Canada at 1-800-333-0510 (1-613-993-9851 in Ottawa region).

CANADIAN RESIDENTS ONLY
DOMICILIÉS DU CANADA SEULEMENT

PRODUCT REGISTRATION CARD
CARTE D'ENREGISTREMENT DU PRODUIT

1. Name
Nom _____

2. Street Address
Adresse _____

3. City _____ 4. Prov. _____
Ville _____ Prov. _____

5. Postal Code
Code postal _____

6. Telephone Number (with Area Code) _____
Num. de téléphone (et indicatif régional) () _____

7. Email Address
Adresse électronique _____

8. Date of Purchase
Date d'achat _____

ATTENTION: This card may be important to the safety of your child. Please complete using blue or black ink and mail this card so that you can be contacted in the event of a safety defect notice on this product. **The information you provide must be complete.** Or register online at www.evenflo.com/registercarseatcanada.

ATTENTION: Cette carte pourrait être importante à la sécurité de votre enfant. Veuillez remplir cette carte à l'encre bleue ou noire et la poster afin de pouvoir être contacté en cas d'un avis de défaut lié à la sécurité de ce produit. **Les informations fournies doivent être complètes.** Ou enregistrez-vous en ligne à www.evenflo.com/registercarseatcanada.

PLACE DATE/MODEL # LABEL HERE.
AFFRER L'ÉTIQUETTE DE LA DATE ET
DU NUMÉRO DE MODÈLE ICI.

Important

Motor Vehicle/Aircraft Usage



When used with the internal harness and properly installed pursuant to these instructions, this restraint is certified for use only in passenger and multi-purpose passenger motor vehicles, buses and trucks equipped with either lap belts only or lap/shoulder belt systems and in aircraft.

Refer to pages 72 - 75 for instructions on installing your child restraint in aircraft.

When used WITHOUT the internal harness system (in booster mode) and properly installed pursuant to these instructions, this restraint is certified for use only in passenger and multi-purpose passenger motor vehicles, buses, and trucks equipped with lap/shoulder belt systems only. In booster mode, this restraint is **NOT** certified for aircraft use. A belt-positioning booster requires the use of a lap/shoulder belt system, which is not available in aircraft.



Child Restraint Features

Front



Description

1. Headrest Adjustment Handle
2. Adjustable Headrest
3. Shoulder Belt Guide
4. Chest Clip
5. Harness Straps
6. Cup Holder (both sides of seat)
7. Harness Release Button (under flap)
8. Recline Handle (under front edge of seat)
9. Harness Adjust Strap
10. Head Pillow*
11. Harness Covers*
12. Headrest Pad
13. Buckle Tongue Pocket (both sides of seat)*
14. Body Pillow
15. Crotch Buckle and Strap

Child Restraint Features

Back

Important

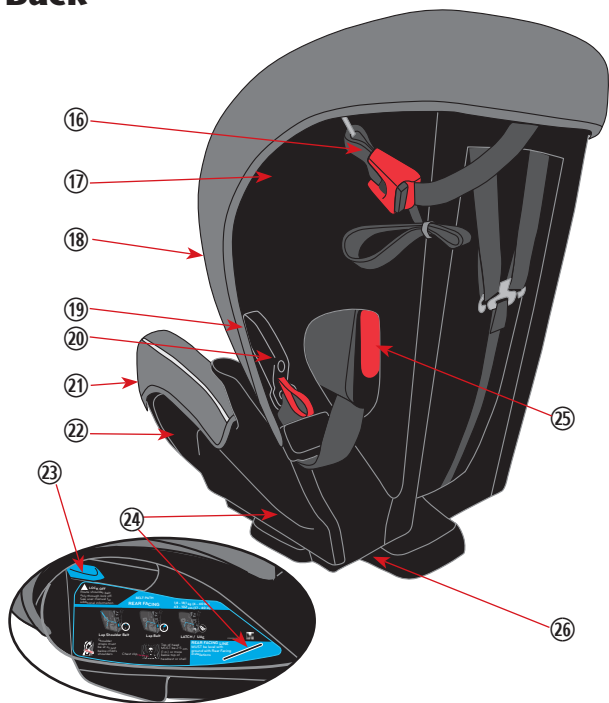

16. Tether Strap and Hook
(shown fastened to storage clip)
17. Instruction Manual Storage
(both sides of seat, see pg 82)
18. Back Pad
19. LATCH (UAS) Storage
(both sides of seat)
20. Lower Anchor (UAS) Connector Assembly
21. Seat Pad
22. Booster Base
23. Rear-facing Lock-off
24. Level Line
25. Forward-facing Lock-off
26. Base

* Not all features are available on all models. Styles may vary.

Child Restraint Features

Cup Holders

⚠ WARNING! DEATH or SERIOUS INJURY can occur.

- Cup holders **MUST** be installed before use of this Child Restraint and **MUST** remain attached to the restraint **AT ALL TIMES** in Rear-Facing mode.
- **DO NOT** use the cup holder to store cans or hard cups.
- **DO NOT** place any cups that contain hot liquids in the cup holder.
- **DO NOT** attach any other items to this child restraint unless it has been certified for use with this specific child restraint.

Install cup holders as shown. Press down to secure, then pull up vertically to ensure proper installation.

To remove, tilt cup holder slightly forward at base, then pull up to release from seat.

NOTE: Cup holders are removable and dishwasher safe (top rack only).



Harness Covers (certain models only)

Install Harness Covers above Chest Clip. Harness covers are optional for added comfort. Wrap Harness Covers around harness straps and attach hook-and-loop strips as shown.

Always check that the harness covers **DO NOT** bunch up when tightening the harness.

Hook-and-loop strips

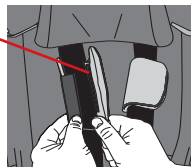

Child Restraint Features

Body Pillow

The optional Body Pillow is for **REAR-FACING** use only and, when placed in the restraint as shown, helps support your child.

When using the lower headrest/harness positions, make sure the bottom of the headrest flap is behind the body pillow flap as shown.

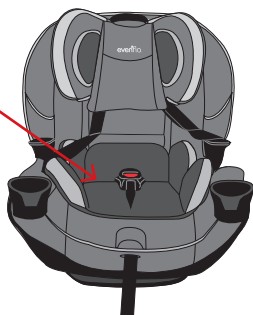

Important

Head Pillow (styles may vary)

The optional head pillow is for **REAR-FACING** use only. The head pillow helps support your child's head.

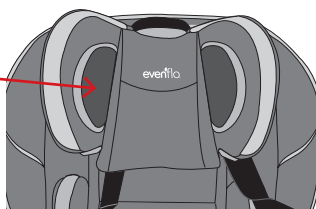

Your head pillow may be one of two different styles. To install:



Slide head pillow into sleeve on headrest as shown.

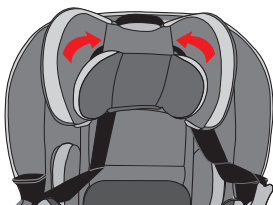

Insert tabs on head pillow into slots on headrest and attach hook-and-loop fasteners to back of headrest.

IMPORTANT: Infants may have difficulty breathing when in an upright seated position. Using additional padding or pillows other than the Head Pillow behind the infant's head or failing to properly recline the child restraint could increase the child's risk of serious injury or death.

Child Restraint Features



Lower Anchor Connector (UAS)

Which Type of Lower Anchor Connector Is on Your Child Restraint?

Your child restraint will have one of the three types of Lower Anchor Connectors (shown below):

1. EasyClick™
2. Quick Connector™ with LATCH/UAS Guide*
3. SecureRight™

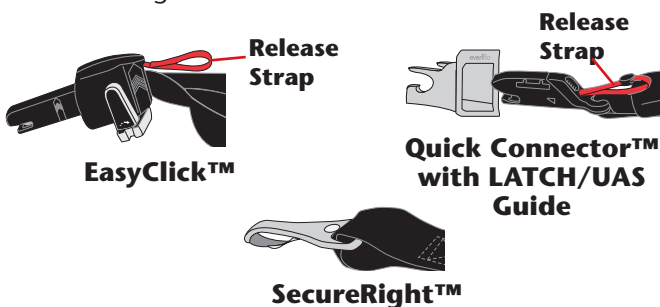

Follow the instructions on the following pages to properly install the Lower Anchor Connector Assembly on your child restraint.

* Guides not available on all models.

Remove Lower Anchor (UAS) Connectors

To remove the lower anchor (UAS) connector from its storage location, pull the red Release Strap. For SecureRight™, push in, squeeze, and twist to remove.

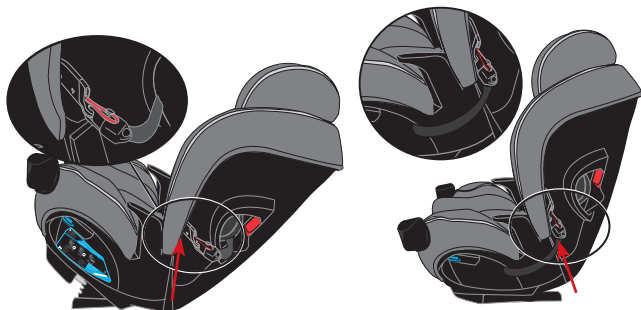

Rear-facing **lower anchor (UAS)** storage

Forward-facing **lower anchor (UAS)** storage

Child Restraint Features

Loosen Lower Anchor (UAS) Connectors

If you have Quick Connector™ or SecureRight™, loosen the lower anchors as shown below:

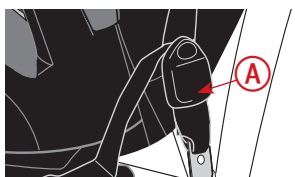

A: Tilt and slide the adjuster to loosen.

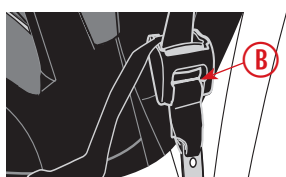

B: Press the adjuster release button to loosen.

Important

Store Lower Anchor (UAS) Connectors

To store the **lower anchor (UAS) connector**, push **UNTIL** it clicks into position as shown below:

Rear-Facing

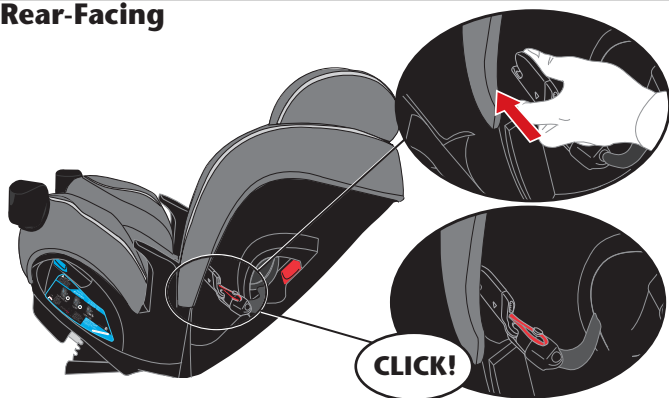

Forward-Facing

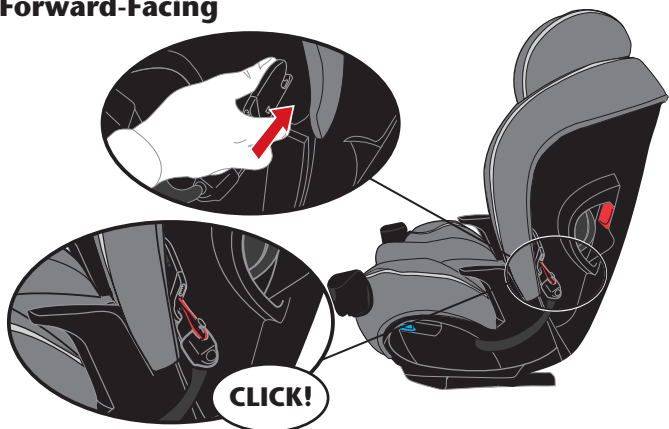

Using the Child Restraint Rear-facing

⚠ WARNING! DEATH or SERIOUS INJURY can occur.

When using this restraint rear-facing, **DO NOT** loosen the vehicle seat belt to provide more leg room as this may keep the child restraint from protecting your child.

Child Requirements:

- **Weight:** 1.8 - 18.1 kg (4 - 40 lbs)
- **Height:** 43 - 102 cm (17 - 40 in.) and top of child's head is at least 2.5 cm (1 in.) or more below the top of child restraint headrest

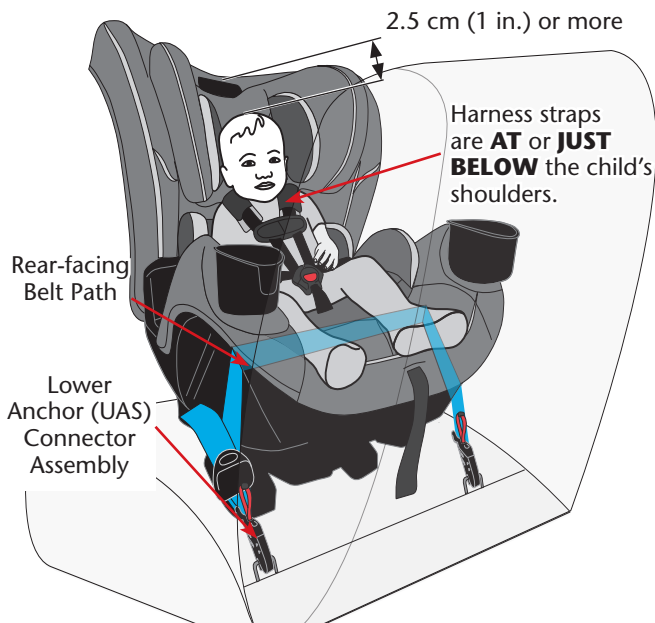
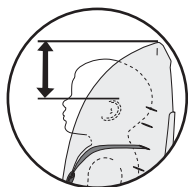

IMPORTANT: Once your child **exceeds** any of the size requirements above, they **MUST** use this child restraint in the **forward-facing** orientation, if possible. If your child **exceeds** any of the size requirements above **and** is less than 2 years old, however, you **MUST** discontinue use of this child restraint.

Rear-facing Installation with Lower Anchor (UAS) Connectors



Moving Lower Anchor Connector Assembly to Rear-facing Belt Path

To access the Lower Anchor Connector Assembly, you will first need to:

- Loosen internal harness straps (pg. 70);
- Remove Lower Anchor Connectors (pg. 24);
- Lift pad off front edge of child restraint. (pg. 78).

To install this child restraint properly in the rear-facing position, the Lower Anchor Connector Assembly **MUST** be in the rear-facing belt path.

(NOTE: illustrations below show pad off for clarity only)

Your car seat comes with the Lower Anchor Connector assembly installed in the rear-facing belt path.

If the Lower Anchor strap is in the forward-facing belt path, follow these steps:

- Lift the seat pad off of the front from the base.
- Pull the Lower Anchor strap to the center of the seat.
- Route the Lower Anchor strap out through the rear-facing belt path.

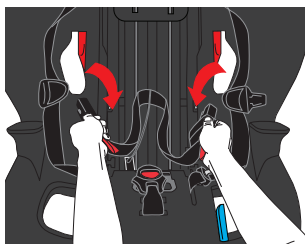

IMPORTANT: The crotch buckle **MUST** be in the **inner slot** when the seat is installed **rear-facing** and the lower anchor (UAS) strap **MUST** be **in front** of the crotch buckle.

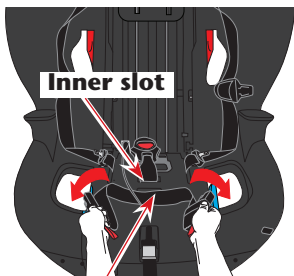

Lower Anchor (UAS) strap

IMPORTANT: Make sure the Lower Anchor Connector strap does not interfere with the internal harness straps.

NOTE: After moving the Lower Anchor Connector strap, make sure the strap lies flat against the seat shell. You may have to twist the strap to achieve this.





Rear-facing Installation with Lower Anchor (UAS) Connectors

ALWAYS store the tether strap (pg. 71). Never use tether strap when child restraint seat is rear-facing.

1. Make sure vehicle is on level ground.
2. Place child restraint **rear-facing** on approved vehicle seat. Always make sure the bottom of the child restraint sits flat on the vehicle seat.
3. Remove Lower Anchor Connectors from sides of the seat (pg. 24). **CHECK** Lower Anchor strap is in rear-facing belt path (pg. 27).
4. Lift up on the recline handle as shown and adjust the seat to one of the three rear-facing recline positions, **so that the level line is parallel to the ground.**

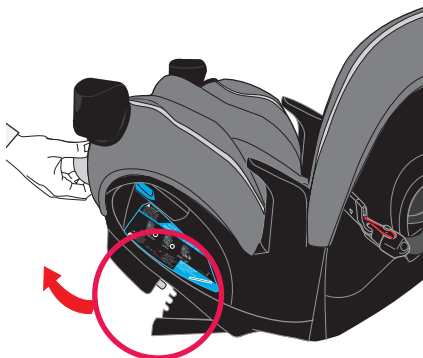

IMPORTANT: Infants may have difficulty breathing when in an upright seated position. Make sure they recline enough for their head to lie back comfortably and safely. Failure to properly recline the child restraint could increase the child's risk of serious injury or death.

5. Ensure child restraint is secure using the appropriate connector on pages 29 - 31, then continue with Steps 6 - 8 on pg. 32.

Rear-facing Installation with Lower Anchor (UAS) Connectors



Restraints with EasyClick™

Lift pad off front edge of seat as shown. Attach lower anchor / UAS connectors to the vehicle lower anchor bars until they lock onto the bars on both sides of the seat.

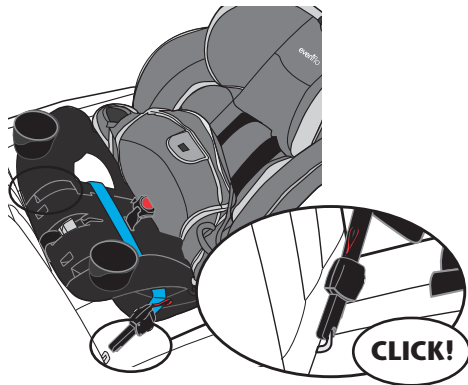

Rear-facing

IMPORTANT: Make sure both lower anchor connectors are facing upward and the straps are not twisted.

EasyClick™

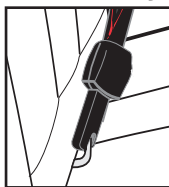

Correct



Incorrect

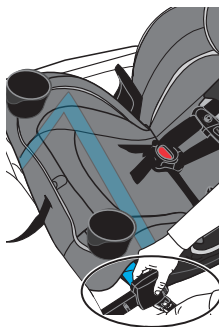

Reconnect the seat pad to the front of the child restraint. Tighten the strap by moving the handle back and forth on the lower anchor connector as shown until the seat is tight.

Fold handle up after tightening.

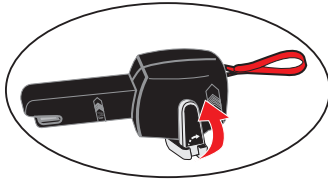
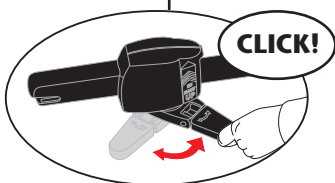



Rear-facing Installation with Lower Anchor (UAS) Connectors

Restraints with Quick Connector™

Install the LATCH/UAS Guides*

⚠ WARNING! DEATH or SERIOUS INJURY can occur.

NEVER use if parts are broken or damaged.

NEVER use LATCH/UAS Guides if they interfere in any way with installation.

Connect one guide, if provided, to each lower anchor by sliding the guide into the vehicle seat crease and under the lower anchor.

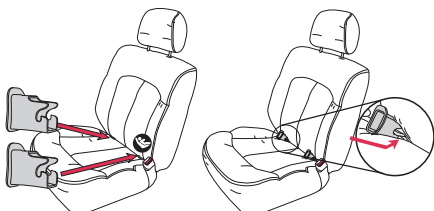

Install the Quick Connectors™

Lift pad off front edge of seat.

Attach lower anchor/UAS connectors to the vehicle lower anchor bars until they lock onto the bars on both sides of the seat.

Reconnect the seat pad to the front of the child restraint.

Using your full weight, push the child restraint firmly into the vehicle seat while pulling up on the Lower Anchor Strap to tighten, as shown.

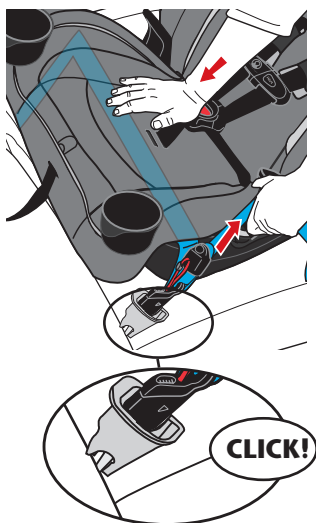

Quick Connector™

IMPORTANT: Make sure both lower anchor connectors are facing upward and the straps are not twisted.

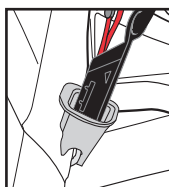

Correct



Incorrect

* Guides not available on all models.

Rear-facing Installation with Lower Anchor (UAS) Connectors



Restraints with SecureRight™

Lift pad off front edge of seat.

Attach lower anchor/UAS connectors to the vehicle lower anchor bars until they lock onto the bars on both sides of the seat.

Reconnect the seat pad to the front of the child restraint.

Using your full weight, push the child restraint firmly into the vehicle seat while pulling up on the Lower Anchor Strap to tighten, as shown.

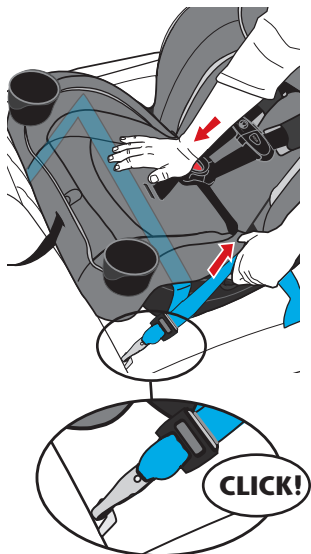

Rear-facing

IMPORTANT: Make sure both lower anchor connectors are facing downward as shown and the straps are not twisted.

SecureRight™

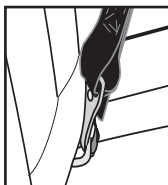

Correct



Incorrect



Rear-facing Installation with Lower Anchor (UAS) Connectors

6. Test for tightness. If you can move the child restraint more than 2.5 cm (1 in.) side to side or front to back at the rear-facing belt path, the lower anchor connector assembly strap is not tight enough.

You will need to try again, find another location for your child restraint, or install with the vehicle seat belt (pg. 33).

Reattach the seat pad.

7. Recheck the level line indicator. Restraint is level when **level line is parallel to the ground.**

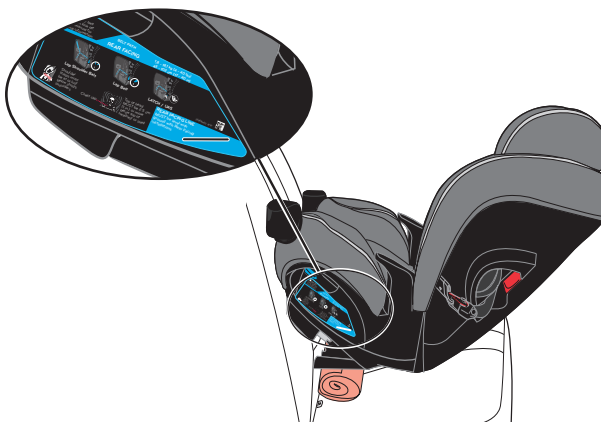

NOTE: In some vehicles, it may be necessary to place a tightly rolled towel or small blanket beneath the front edge of the child restraint to provide enough recline so that the level line is parallel to the ground.

8. To remove the lower anchor connector, pull red release strap, or for SecureRight™, push in, squeeze, and twist to remove.
9. Remove the connector on the opposite side of the seat from the vehicle anchor.

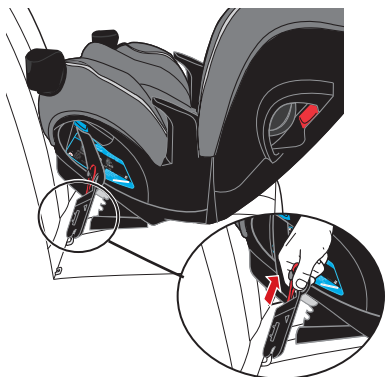

Rear-facing Installation with Vehicle Seat Belts



IMPORTANT:

- Before installing this child restraint **rear-facing with the vehicle seat belt**, you **MUST** move the Lower Anchor Connector Assembly (UAS) to the **forward-facing belt path** so that it does not interfere with the vehicle seat belt. Refer to pg. 39 for instructions on moving the Lower Anchor Connector Assembly (UAS) to the forward-facing belt path.
- Check your vehicle owner's manual to determine how to lock your seat belt for child restraint installation. If vehicle permits, the retractor must be locked.
- **DO NOT** use the Tether Strap when the child restraint is in the rear-facing position. Store tether (pg. 71).

1. Make sure vehicle is on level ground.
2. Place child restraint **rear-facing** on approved vehicle seat. Always make sure the bottom of the child restraint sits flat on the vehicle seat.
3. Reroute the lower anchor connector strap through the forward-facing belt path (pg. 39). Store the lower anchor connector (UAS) as shown.

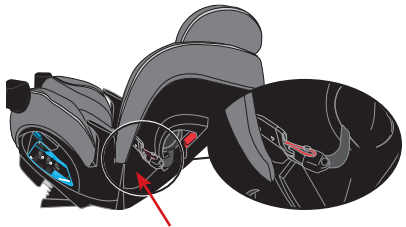

Rear-facing **lower anchor (UAS)** storage

4. Lift up on the recline handle as shown and adjust the seat to one of the three rear-facing recline positions, **so that the level line is parallel to the ground.**

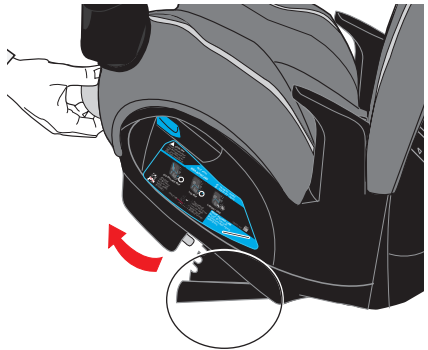



Rear-facing Installation with Vehicle Seat Belts

IMPORTANT: Infants may have difficulty breathing when in an upright seated position. Make sure they recline enough for their head to lie back comfortably and safely. Failure to properly recline the child restraint could increase the child's risk of serious injury or death.

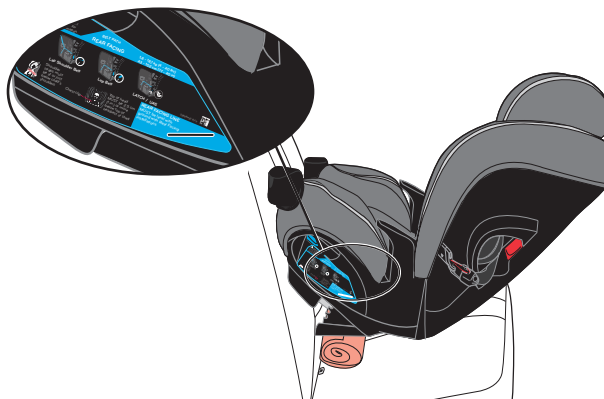

NOTE: In some vehicles, it may be necessary to place a tightly rolled towel or small blanket beneath the front edge of the child restraint to provide enough recline so that the level line is parallel to the ground.

5. Ensure child restraint is secure.
 - For **Rear-Facing Installation with Lap Belt**, see pg. 35.
 - For **Rear-Facing Installation with Lap/Shoulder Belt**, see pg. 36.

Rear-facing Installation with Vehicle Seat Belts



Rear-facing Installation with Lap Belt

Pull the seat pad off of the front of the child restraint. Route the lap belt through the rear-facing belt path and continue through the opposite opening of the child restraint. Fasten the buckle.

IMPORTANT: The crotch buckle must be in the inner slot and the vehicle belt must be located in front of the buckle.

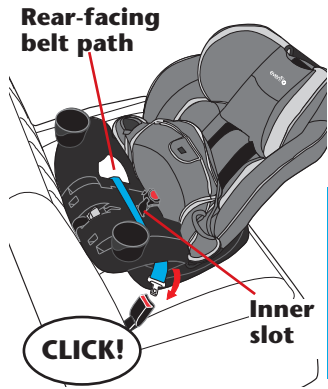

Rear-facing

Reconnect the seat pad to the front of the child restraint.

The vehicle seat belt must be as tight as possible. Using your full weight, push the child restraint firmly into the vehicle seat as you tighten the vehicle **seat belt**, as shown.

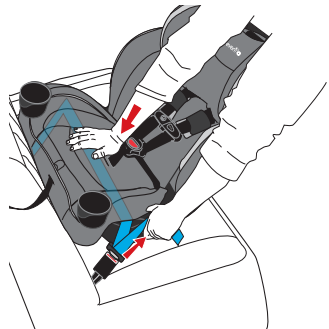

DO NOT use lock-off with lap belt only installation.

Check your work. Make certain the belt is tight and locked. If you can move the child restraint more than 2.5 cm (1 in.) side to side or front to back at the rear-facing belt path, the vehicle belt is not tight enough.

Recheck level line (pg. 32). If you have not tightly secured the child restraint, try again, move it to another location, or install with the lower anchor connector assembly (pg. 28).

To remove seat, unbuckle vehicle seat belt.



Rear-facing Installation with Vehicle Seat Belts

Rear-facing Installation with Lap/Shoulder Belt

Pull the seat pad off of the front of the child restraint. Route the vehicle belt through the rear-facing belt path and continue through the opposite belt path on the child restraint. Fasten the buckle.

IMPORTANT: The crotch buckle must be in the inner slot and the vehicle belt must be located in front of the crotch buckle strap.

Reconnect the seat pad to the front of the child restraint.

The vehicle seat belt must be as tight as possible. Using your full weight, push the child restraint firmly into the vehicle seat as you tighten the **seat belt**, as shown.

Insert the shoulder belt into the rear-facing lock-off on the side of the restraint opposite the seat belt buckle. Holding the seat shell, pull shoulder belt firmly in the direction of the retractor. The shoulder belt **MUST** be routed through the lock-off. If vehicle permits, the retractor must be locked (pg. 12).

Check your work. Make certain the belt is tight and locked. If you can move the child restraint more than 2.5 cm (1 in.) side to side or front to back at the rear-facing belt path, the vehicle belt is not tight enough.

Recheck level line (pg. 32). If you have not tightly secured the child restraint, try again, move it to another location, or install with the lower anchor connector assembly (pg. 28).

To remove seat, unbuckle vehicle seat belt.

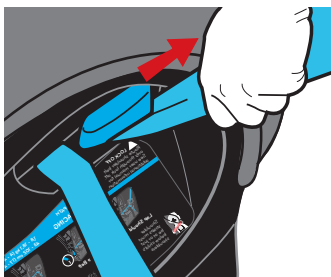
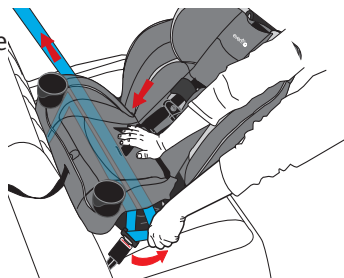
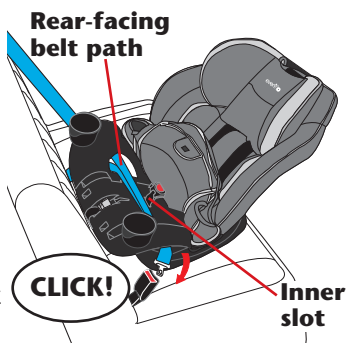

Rear-facing Installation Checklist

1. Secure child restraint to the vehicle seat.

- ✓ Child restraint is in one of the three rear-facing recline positions, **so that the level line is parallel to the ground** (pg. 28).
- ✓ Towel rolled up and placed beneath the base, if necessary, **so that the level line is parallel to the ground** (pg. 32).
- ✓ Install with Lower Anchor Connector (UAS) Assembly (pg. 27) **or** vehicle seat belt (pg. 33).
- ✓ To properly secure this child restraint it **MUST NOT** move more than 2.5 cm (1 in.) from side to side or front to back at the rear-facing belt path (pgs. 32, 35, and 36).
- ✓ Shoulder belt is routed through rear-facing lock-off when installing with lap/shoulder belt. It is recommended to lock retractor in addition to using the lock-off, if vehicle permits (pg. 36).
- ✓ Cupholders **MUST** be installed (pg. 22).

2. Set the child in the child restraint.

- ✓ Top of head is at least 2.5 cm (1 in.) or more below the top of headrest
- ✓ Install Body Pillow if necessary (pg. 23).
- ✓ The child's back and bottom are flat against the back and bottom surfaces of the child restraint.
- ✓ Harness straps **MUST** be at or just below shoulder height (pg. 26).

3. Fasten the buckle.

- ✓ Buckle tongues are fully engaged (pg. 69).

4. Make necessary adjustments.

- ✓ Crotch buckle **MUST** be in inner slot (pg. 67).
- ✓ Harness straps **MUST** be snug against the child's shoulders, with no slack (pg. 69).

5. Position and connect chest clip.

- ✓ Chest clip **MUST** be at armpit level (pg. 69).

Using the Child Restraint Forward-facing with Harness

Child Requirements:

- **Weight:** 10 - 29.5 kg (22 - 65 lbs)
- **Height:** 71 - 124 cm (28 - 49 in.) and tops of child's ears are at or below the top of the child restraint headrest.
- **Age:** At least 2 years old

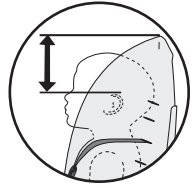

IMPORTANT: ALWAYS USE THE TOP ANCHORAGE (TETHER) STRAP.

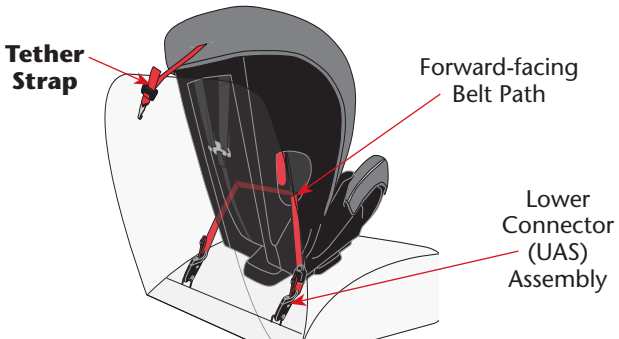
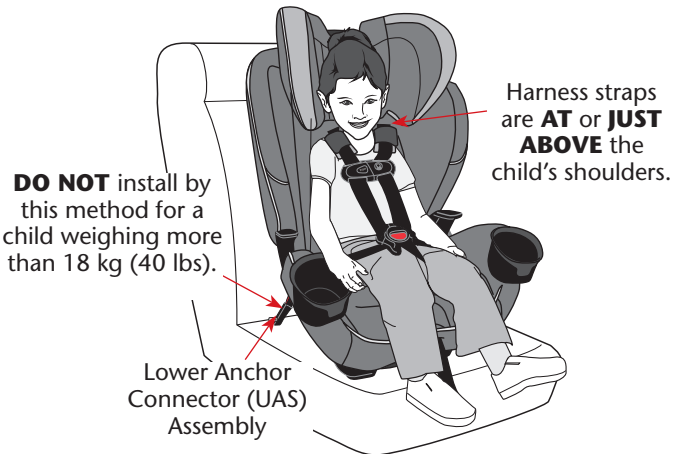

IMPORTANT: Once your child **exceeds** any of the size requirements for **forward-facing with harness** use above, and is at least 4 years old, you **MUST** discontinue use of this child restraint with its internal harness and begin using it in booster mode.

Forward-facing Installation with Lower Anchor (UAS) Connectors



Moving Lower Anchor Connector Assembly to Forward-facing Belt path

To access the Lower Anchor Connector Assembly, you will first need to remove the Lower Anchor Connectors from its storage location (see pg. 24).

(Illustrations below show pad off for clarity only)

To install this child restraint properly in the forward-facing position, the Lower Anchor Connector (UAS) Assembly **MUST** be in the forward-facing belt path.

If the Lower Anchor Connector strap is in the rear-facing belt path, follow these steps:

- Raise the headrest to its highest level (pg. 65).
- Lift the headrest pad up and out of the way (pg. 57).
- Lift the seat pad off the front of the base.
- Pull the Lower Anchor Connector strap to the center of the seat.
- Route the Lower Anchor Connector strap out through the forward-facing belt path.
- Reattach the seat pad.

IMPORTANT: Make sure the Lower Anchor Connector strap does not interfere with the internal harness straps.

NOTE: After moving the Lower Anchor Connector strap, make sure the strap lies flat against the seat shell. You may have to twist the strap to achieve this.

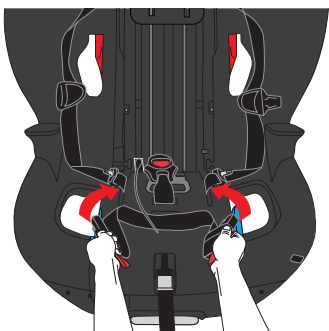

Forward-Facing

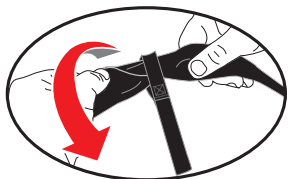
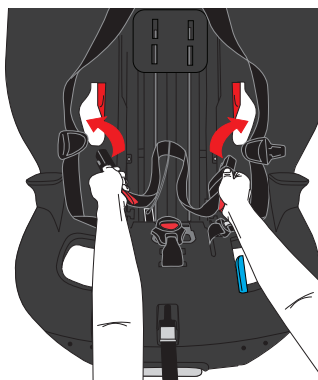



Forward-facing Installation with Lower Anchor (UAS) Connectors

DO NOT install by this method for a child weighing more than 18 kg (40 lbs).

Infants who weigh less than 10 kg (22 lbs) **MUST** always be rear-facing.

If a tether anchor is not available, **ALWAYS** store the Tether Strap (pg. 71).

1. Remove Lower Anchor Connectors from storage location (pg. 24). **MAKE SURE** Lower Anchor strap is in forward-facing belt path (pg. 39).

2. Lift up on the recline handle as shown and adjust the seat recline to the upright position.

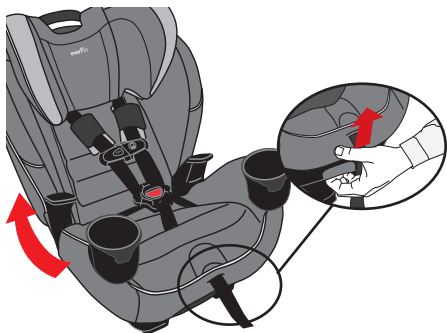

3. Place child restraint in your vehicle **forward-facing**, as shown. Always make sure the bottom of the child restraint sits flat on the vehicle seat.

4. Unhook tether strap from the rear of the child restraint and place tether hook with **red adjuster** (pg. 71) over back of vehicle seat.



5. Ensure child restraint is secure using the appropriate connector on pages 41 - 43, then continue with Steps 6 - 8 on pages 43 - 45.

Forward-facing Installation with Lower Anchor (UAS) Connectors



Restraints with EasyClick™

Attach lower anchor (UAS) connectors to the vehicle lower anchor bars until they lock onto the bars on both sides of the seat.

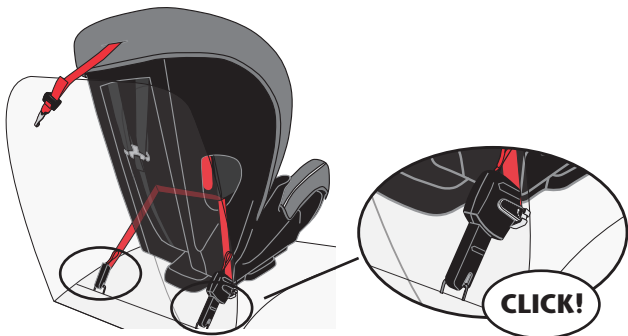

IMPORTANT: Make sure both lower anchor connectors are facing upward and the straps are not twisted.

EasyClick™

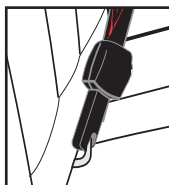

Correct



Incorrect

Forward-Facing

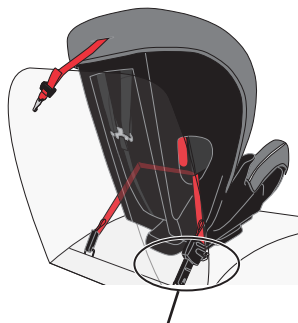

Tighten the strap by moving the handle back and forth on the lower anchor connector as shown until the seat is tight.

Fold handle up after tightening.

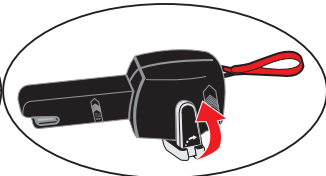
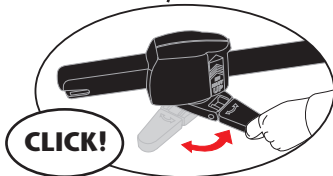



Forward-facing Installation with Lower Anchor (UAS) Connectors

Restraints with Quick Connectors™

Install the LATCH/UAS Guides*

! WARNING! DEATH or SERIOUS INJURY can occur.

NEVER use if parts are broken or damaged.

NEVER use LATCH/UAS Guides if they interfere in any way with installation.

Connect one guide, if provided, to each lower anchor by sliding the guide into the vehicle seat crease and under the lower anchor.

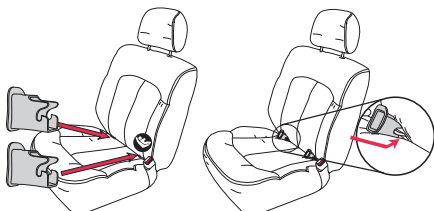

Install the Quick Connectors™

Attach lower anchor / UAS connectors to the vehicle lower anchor bars until they lock onto the bars on both sides of the seat.

Using your full weight, push the child restraint firmly into the vehicle seat while pulling up on the Lower Anchor Strap to tighten and remove all slack, as shown.

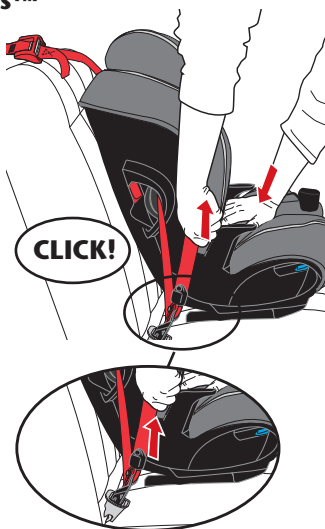

Quick Connector™

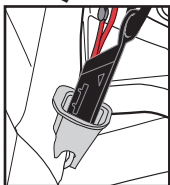

Correct



Incorrect

IMPORTANT: Make sure both lower anchor connectors are facing upward and the straps are not twisted.

* Guides not available on all models.

Forward-facing Installation with Lower Anchor (UAS) Connectors



Restraints with SecureRight™

Attach lower anchor / UAS connectors to the vehicle lower anchor bars until they lock onto the bars on both sides of the seat.

Using your full weight, push the child restraint firmly into the vehicle seat while pulling up on the Lower Anchor Strap to tighten and remove all slack, as shown.



SecureRight™

IMPORTANT: Make sure both lower anchor connectors are facing downward and the straps are not twisted.

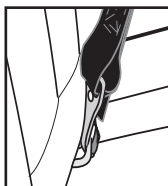

Correct



Incorrect

- 6. Test for tightness.** If you can move the child restraint more than 2.5 cm (1 in.) side to side or front to back at the forward-facing belt path, the lower anchor connector assembly strap is not tight enough.

You will need to try again, find another location for your child restraint, or install with the vehicle seat belt (pg. 46).

Continue with Step 7 (pg. 45) to attach tether strap.



Forward-facing Installation with Lower Anchor (UAS) Connectors



Attaching Tether Straps

! WARNING! DEATH or SERIOUS INJURY can occur.

- Failure to follow these instructions could result in serious injury to your child or other vehicle occupants.
- The tether strap is for **forward-facing use only**.
- To avoid a strangulation hazard, you **MUST** tightly roll or fold excess tether strap and secure with the strap/rubber band.
- The tether is not used in rear-facing mode. Attach the tether hook to the storage clip on the seat in rear-facing mode only. This will keep an unused tether or tether hook from hitting someone during a crash. After adjusting the tether strap, you may have excess strap; **DO NOT** cut it off. If you do, it may not be long enough to use in another vehicle. Instead, tightly roll up the excess tether strap and place the rubber band around the bundle.

NOTE: Refer to your vehicle owner's manual for the location of the tether anchor in your vehicle. Older vehicles may not come equipped with tether anchor hardware. Check with your vehicle dealer.

- The Tether Strap **MUST** be used when installing this child restraint forward-facing.
- If your Tether Strap is too short to reach from your child restraint to your Tether Anchor, you will need a Tether Extender. Please call Parentlink at 1-800-233-5921 (U.S.), 1-937-773-3971 (Canada), or 01-800-706-12-00 (Mexico).

Forward-facing Installation with Lower Anchor (UAS) Connectors



Attaching Tether Straps



7. Connect the tether hook to the vehicle tether anchor behind the vehicle seat, as shown. (Please consult your vehicle owner's manual, as tether anchor locations may vary.) Pull the strap and tighten the tether securely.

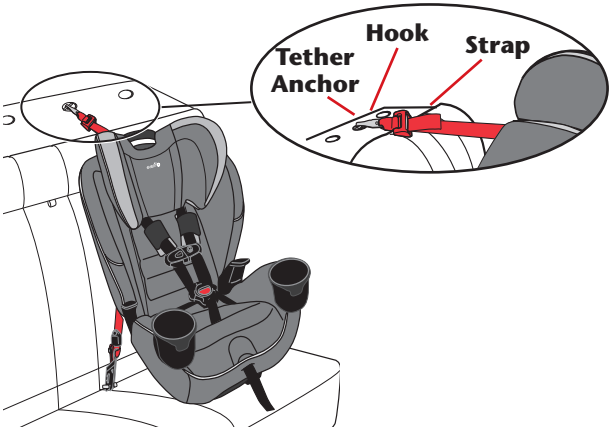

8. To remove the lower anchor connector, pull red release strap, or for SecureRight™, push in, squeeze, and twist to remove.
9. Remove the connector on the opposite side of the seat from the vehicle anchor.

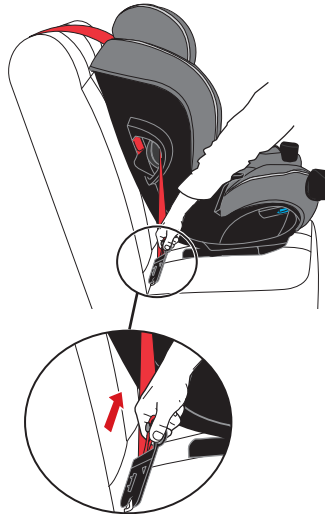

Forward-Facing



Forward-facing Installation with Vehicle Seat Belts

IMPORTANT:

- Before installing this child restraint **forward-facing with the vehicle seat belt**, you **MUST** move the Lower Anchor Connector (UAS) Assembly to the **rear-facing belt path** so that it does not interfere with the vehicle seat belt. Refer to pg. 27 for instructions on moving the Lower Anchor Connector Assembly (UAS) to the rear-facing belt path.
 - Check your vehicle owner's manual to determine how to lock your seat belt for child restraint installation. If vehicle permits, the retractor must be locked..
 - **ALWAYS** use tether strap. Store tether strap when not in use (pg. 71).
1. Reroute the lower anchor connector strap through the rear-facing belt path (pg. 27). Store the lower anchor connector (UAS) in the rear-facing belt path as shown.

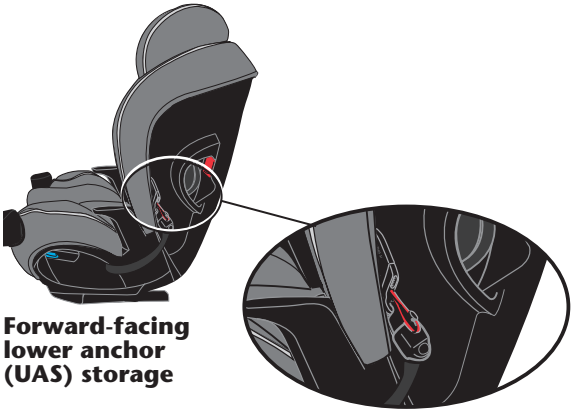

**Forward-facing
lower anchor
(UAS) storage**

Forward-facing Installation with Vehicle Seat Belts



2. Lift up on the recline handle as shown and adjust the seat recline to the upright position.

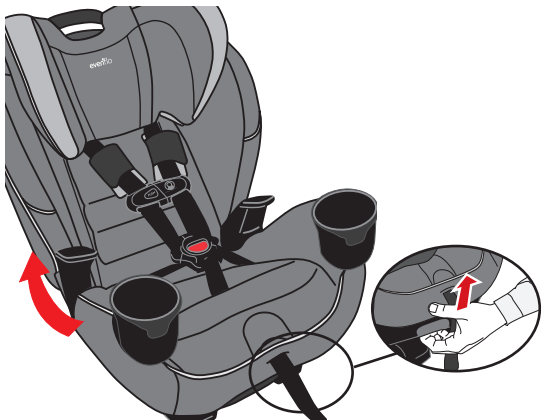

3. Place child restraint in your vehicle **forward-facing**, as shown. Always make sure the bottom of the child restraint sits flat on the vehicle seat.

Unhook tether strap from the rear of the child restraint and place tether hook with **red adjuster** (pg. 71) over back of vehicle seat.



4. Ensure child restraint is secure.
 - For **Forward-Facing Installation with Lap Belt**, see pg. 48.
 - For **Forward-Facing Installation with Lap/Shoulder Belt**, see pg. 49.



Forward-facing Installation with Vehicle Seat Belts

Forward-facing with Lap Belt Only

Raise headrest to its highest position (pg. 65), then lift headrest pad away from child restraint for easier access. Route the lap belt through the forward-facing belt path and continue through the opposite opening of the child restraint. Fasten the buckle.

IMPORTANT: Make sure the lap belt lies flat without twisting.

DO NOT use the lock-off with lap belt only installation.

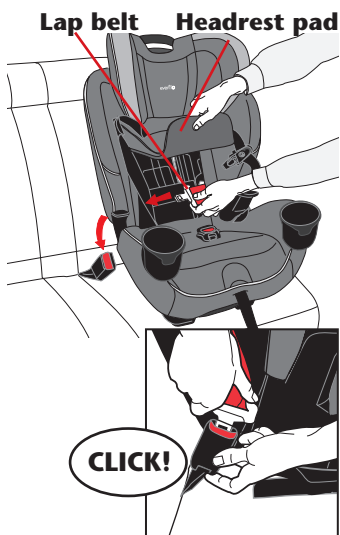

The vehicle seat belt must be as tight as possible. Using your full weight, push the child restraint firmly into the vehicle seat as you tighten the vehicle **seat belt**, as shown. Lower the headrest pad.



Check your work. Pull on the belt to make sure it's tight and locked. If you can move the child restraint more than 2.5 cm (1 in.) side to side or front to back at the forward-facing belt path, the vehicle belt is not tight enough. If you have not tightly secured the child restraint, try again, move it to another location, or install with the lower anchor connector assembly (pg. 40).

Continue with Step 5 (pg. 51) to attach tether strap.

Forward-facing Installation with Vehicle Seat Belts



Forward-facing with Lap/Shoulder Belt

Raise headrest to its highest position (pg. 65), then lift headrest pad away from child restraint for easier access. Route the lap/shoulder belt through the forward-facing belt path and continue through the opposite opening of the child restraint. Fasten the buckle.

IMPORTANT: Make sure the lap/shoulder belt lies flat without twisting.

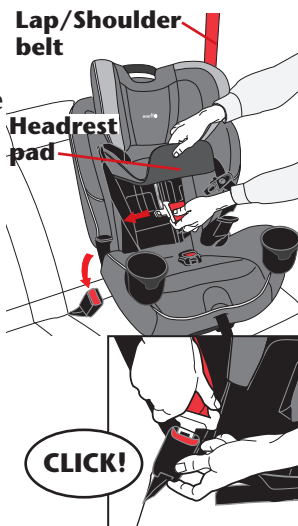

The vehicle seat belt must be as tight as possible. Using your full weight, push the child restraint firmly into the vehicle seat as you tighten the vehicle **seat belt**, as shown. Lower the headrest pad.

Insert the shoulder belt into the forward-facing lock-off on the side of the restraint opposite the seat belt buckle. The shoulder belt **MUST** be routed through the lock-off. If vehicle permits, the retractor must be locked (pg. 12).

Check your work. Pull on the belt to make sure it's tight and locked. If you can move the child restraint more than 2.5 cm (1 in.) side to side or front to back at the forward-facing belt path, the vehicle belt is not tight enough. If you have not tightly secured the child restraint, try again, move it to another location, or install with the lower anchor connector assembly (pg. 40).

Continue with Step 5 (pg. 51) to attach tether strap.





Forward-facing Installation with Vehicle Seat Belts



Attaching the Tether Strap

⚠ WARNING! DEATH or SERIOUS INJURY can occur.

- Failure to follow these instructions could result in serious injury to your child or other vehicle occupants.
- The tether strap is for **forward-facing use only**.

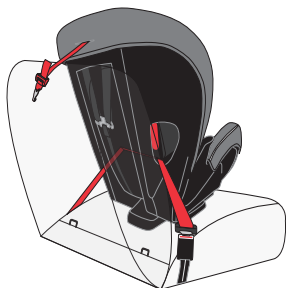

Lap Belt

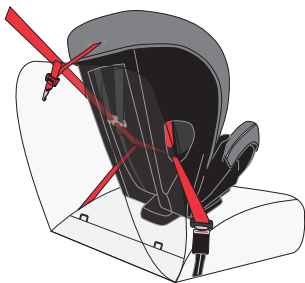

Lap/Shoulder Belt

- To avoid a strangulation hazard, you **MUST** tightly roll or fold excess tether strap and secure with the strap/rubber band.
- The tether is not used in rear-facing mode. Attach the tether hook to the storage clip on the seat in rear-facing mode only. This will keep an unused tether or tether hook from hitting someone during a crash. After adjusting the tether strap, you may have excess strap; **DO NOT** cut it off. If you do, it may not be long enough to use in another vehicle. Instead, tightly roll up the excess tether strap and place the rubber band around the bundle.

NOTE: Refer to your vehicle owner's manual for the location of the tether anchor in your vehicle. Older vehicles may not come equipped with tether anchor hardware. Check with your vehicle dealer.

- The Tether Strap **MUST** be used when installing this child restraint forward-facing with a vehicle seat belt.
- If your Tether Strap is too short to reach from your child restraint to your Tether Anchor, you will need a Tether Extender. Please call Parentlink at 1-800-233-5921 (U.S.) or 1-937-773-3971 (Canada), or 01-800-706-12-00 (Mexico).

Forward-facing Installation with Vehicle Seat Belts



Attaching the Tether Strap



5. Connect the tether hook to the vehicle tether anchor behind the vehicle seat, as shown. (Please consult your vehicle owner's manual, as tether anchor locations may vary.) Pull the strap and tighten the tether securely.

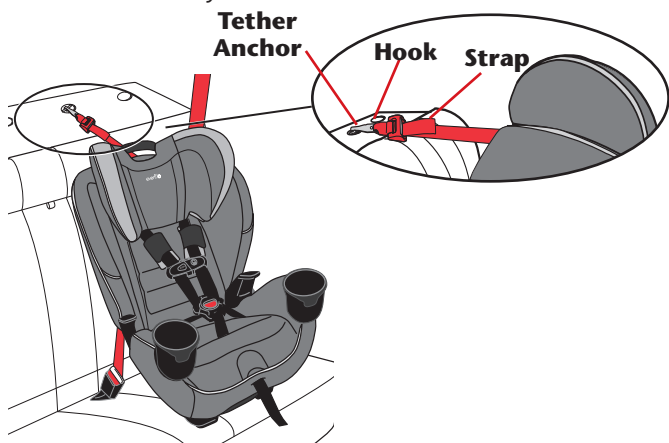

6. To remove the seat, unbuckle the vehicle belt, and unhook the tether strap.

Forward-facing Installation Checklist

1. Secure child restraint to the vehicle seat.

- ✓ Child restraint is in the upright position.
- ✓ Child restraint base sits flat on vehicle seat.
- ✓ To properly secure this child restraint it **MUST NOT** move more than 2.5 cm (1 in.) from side to side or front to back at the forward-facing belt path (pgs. 43, 48, and 49).
- ✓ Install with Lower Anchor connector Assembly (pg. 40) **or** vehicle seat belt (pg. 46).
- ✓ Tether strap is securely attached and tightened (pgs. 44 or 50).
- ✓ Shoulder belt is routed through forward-facing lock-off when installing with lap/shoulder belt. It is recommended to lock retractor in addition to using the lock-off, if vehicle permits (pg. 49).

2. Set the child in the child restraint.

- ✓ The top of the child's ears are at or below the top of the child restraint headrest.
- ✓ The child's back and bottom are flat against the back and bottom surfaces of the child restraint.
- ✓ Harness straps **MUST** be at or just above shoulder height (pg. 38).

3. Fasten the buckle.

- ✓ Buckle tongues are fully engaged (pg. 69).

4. Make necessary adjustments.

- ✓ Crotch buckle in the correct position (pg. 67).
 - Inner slot: children who weigh less than 30 lbs (13.6 kg).
 - Outer slot: children who weigh 30 lbs (13.6kg) or more.
- ✓ Harness straps **MUST** be snug against the child's shoulders, with no slack (pg. 69).

5. Position and connect chest clip.

- ✓ Chest clip **MUST** be at armpit level (pg. 69).

Using the Child Restraint as a Booster Seat

When to Put Your Child in a Booster Seat



Booster seats raise the child up and help to position the vehicle lap and shoulder belt correctly. When the child is properly restrained in a booster seat, their risk of injury in all types of crashes is reduced, as the lap and shoulder belt provides excellent restraint of both the upper and lower torsos.

It is important for the child to sit properly within the vehicle seat belts. When the vehicle belt is buckled, the lap belt should be low on the hips, just touching the thighs, and the shoulder belt should lie across the middle of the shoulder. If the child leans out or moves the belt behind the back or places it under the arm, it will not provide the intended restraint.

There are a number of things to consider when deciding whether a child is ready to sit in a booster seat, including: the weight and height ratings on their current child seat, the child's own weight and height, their maturity, and the seating positions available in your vehicle.

How is a booster seat used?

Using a booster seat is very similar to buckling yourself into the vehicle:

- Read the instruction manuals for both the booster seat and the vehicle before you start.
- Put the booster in the back seat in a location with a lap and shoulder belt. **Never use a booster with only a lap belt**, as this could cause serious injuries.
- After the child is in the booster, pull the lap and shoulder belt across him/her and buckle it.



When to Put Your Child in a Booster Seat

- Check that the shoulder belt lies across the middle of the shoulder and that the lap belt is low on the hips, just touching the thighs.
- Base of booster should be flat on vehicle seat.

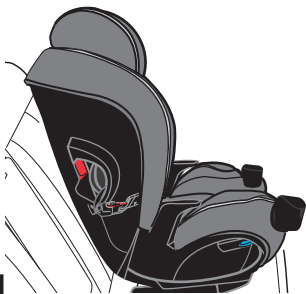

How can you tell if a child is ready to transition to a booster seat?

You should consider using a booster seat if the following conditions apply:

- The child is mature enough to sit in the booster seat and not put the belts under their arm or behind their back.
- The child is approaching the weight or height limit of the child restraint they are currently using. (Even children who have not outgrown their toddler seat can benefit from the use of a booster seat, if it is used properly.)
- If you have a vehicle that does not have a tether anchorage but has lap/shoulder belts available in the back seat, a booster seat may provide better protection than an internal harness seat without the tether.

Using Your Booster Seat in High-Back Mode

Child Requirements

- **Weight:** 18 - 54.4 kg (40 - 120 lbs)
- **Height:** 112 - 145 cm (44 - 57 in.)
AND tops of the child's ears are at or below the top of the booster seat headrest.
- **Age:** At least 4 years old

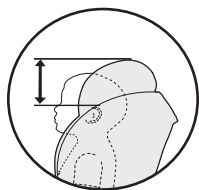

The shoulder belt **MUST** pass through shoulder belt guide and the belt guide should be **even with or just above** the shoulders.

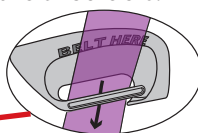
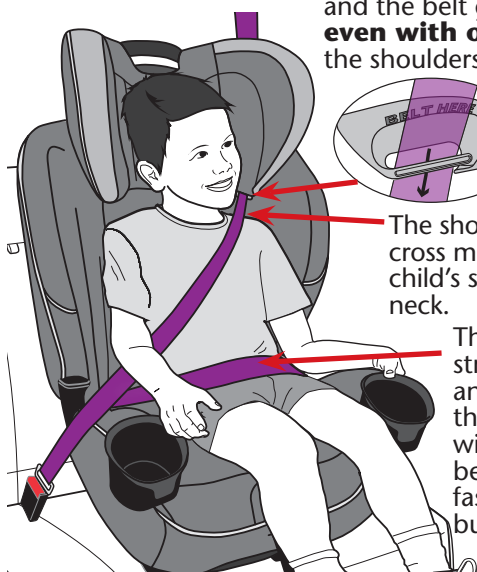

Rear view of belt guide

The shoulder belt **MUST** cross midway between child's shoulder and neck.

The lap belt is stretched low and snug across the child's hips, within the lower belt guides, and fastened into the buckle.

IMPORTANT: Once your child **exceeds** any of the size requirements above for **booster mode**, you **MUST** discontinue use of this seat. Your child may be ready for use of the vehicle belt system only at this time.

Using Your Booster Seat in High-Back Mode

Converting Seat into High-Back Booster

1. Loosen harness straps by pushing the harness release button on the front of the seat. At the same time, pull harness straps to extend completely.

Unfasten the chest clip and buckle.

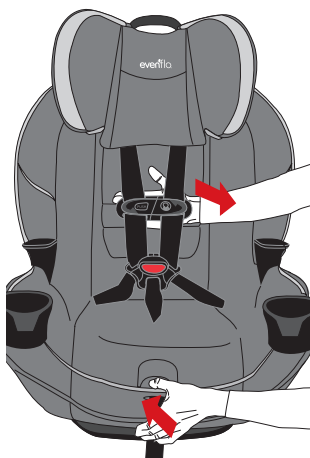

2. Remove the crotch buckle from the slot.
 - Remove the seat base from the booster back. See pg. 60.
 - Remove crotch buckle. See "Adjusting Crotch Buckle Position" on pg. 67.
 - Reattach the seat back. See pg. 63.

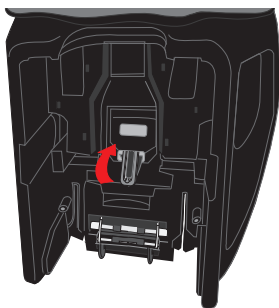

3. Store crotch buckle by inserting anchor into slot at rear of seat base and placing buckle in storage space as shown.

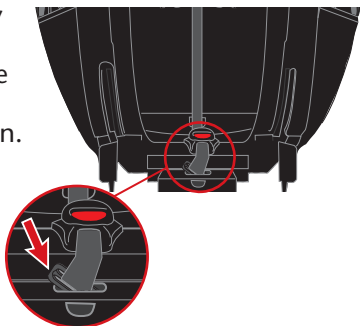

Using Your Booster Seat in High-Back Mode

Converting Seat into High-Back Booster

4. Lift up headrest pad. Disconnect hook-and-loop connectors on seat pad.

Push the shoulder straps behind the headrest pad.

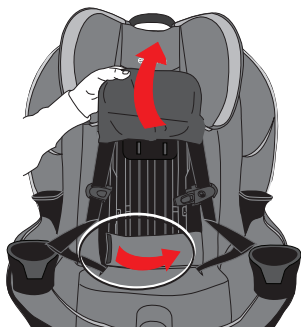

5. Pull harness straps, chest clip, and buckle tongues through the forward-facing belt guides. Snap the two halves of the chest clip together behind the seat.

NOTE: Raise headrest to desired height before connecting chest clip.

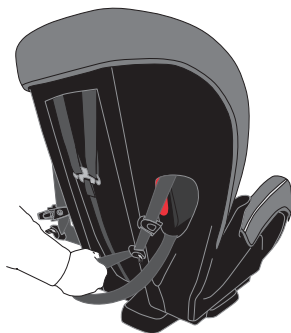

6. Replace headrest pad.
7. Adjust booster seat to the upright position. High-Back Booster Mode is complete.

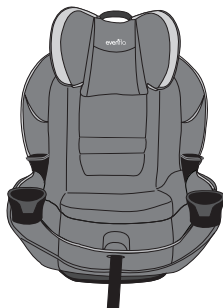

Booster

Convert from High-Back Booster to Harness Mode

- Disconnect chest clip from back of seat.
- Lift up headrest and pull shoulder straps through forward-facing belt guides.
- Remove crotch buckle from slot at rear of seat base and replace into proper crotch buckle slot (p. 67). Replace seat back (p. 60).
- Raise headrest to desired height.

High-Back Booster Installation Checklist

- 1. Convert child restraint to booster seat.**
 - ✓ See "Converting Seat Into High-Back Booster" (pg. 56).
- 2. Secure booster seat to the vehicle seat.**
 - ✓ Make sure the seat base is flat on vehicle seat in the upright position only (pg. 54). Make sure the bottom and back of the booster seat are touching vehicle seat and back.
 - IMPORTANT:** You may use the Tether Strap and Lower Anchor Connectors to secure this booster seat to the vehicle seat as long as the position of the booster seat in the vehicle and/or the resulting fit of the vehicle seat belt over the child are not affected.
- 3. Place the child in the booster seat.**
 - ✓ Make sure the booster seat is securely locked into the upright position and the child's back and bottom are flat against the back and bottom surfaces of the booster seat.
- 4. Adjust headrest for proper shoulder belt fit.**
 - ✓ The shoulder belt **MUST** cross midway between the child's shoulder and neck.

⚠ WARNING! DEATH or SERIOUS INJURY can occur.

The shoulder belt **MUST NOT** cross the child's neck or fall off the child's shoulder. If you cannot adjust the shoulder belt to properly lay midway between the child's shoulder and neck **AND** at or above the shoulder, try another seating location or do not use the booster seat.



- 5. Secure child and booster seat to vehicle seat.**
 - ✓ Stretch the lap/shoulder belt across the child and fasten the buckle. Make certain the shoulder belt is threaded through the shoulder belt guide.
- 6. Check your work.**
 - ✓ Make sure the lap belt is stretched low and snug across the child's hips, within the lower belt guides, and fastened into the buckle. The shoulder belt must cross the child midway between his/her shoulder and neck.

Using Your Booster Seat in Backless Booster Mode

Child Requirements

- **Weight:** 18 - 54.4 kg (40 - 120 lbs)
- **Height:** 112 - 145 cm (44 - 57 in.)
AND tops of the child's ears are at or below the top of the vehicle seat headrest.
- **Age:** At least 4 years old

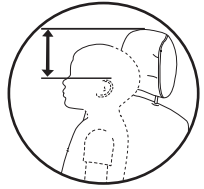

The shoulder belt **MUST** cross midway between child's shoulder and neck. Use shoulder belt clip, if necessary.

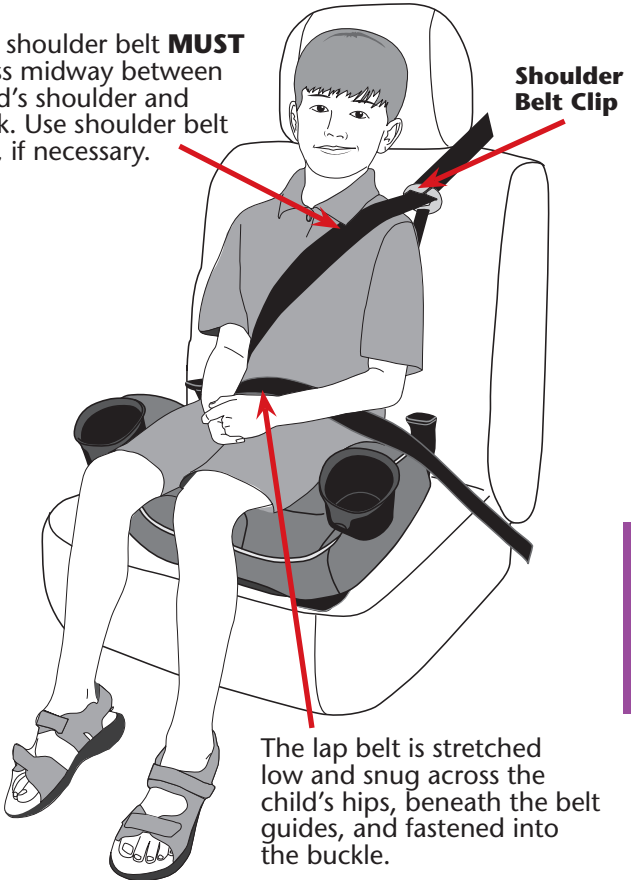

Booster

IMPORTANT: Once your child **exceeds** any of the size requirements above for **booster mode**, you **MUST** discontinue use of this seat. Your child may be ready for use of the vehicle belt system only at this time.

Using Your Booster Seat in Backless Booster Mode

Converting Seat into Backless Booster

1. Lay the booster seat on its back.

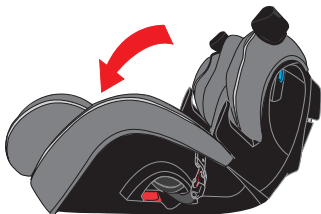

2. Lift up panel in seat pad to access release handle.

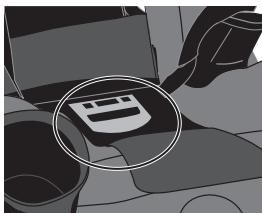

3. Lift up and hold release handle. Hold booster by armrests and lift booster base off of seat back.

NOTE: If crotch buckle is still attached, remove and store by following directions on pg. 56.

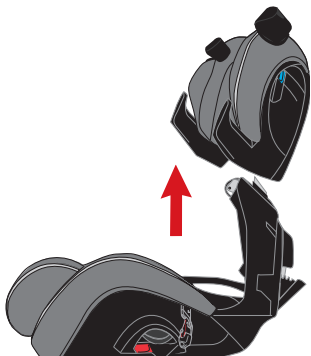

IMPORTANT: Move user guide to storage slots underneath base.

IMPORTANT: Store the backrest properly when not in use and do not leave in the vehicle (other than in trunk). Any loose objects can become projectiles and injure someone during a crash.

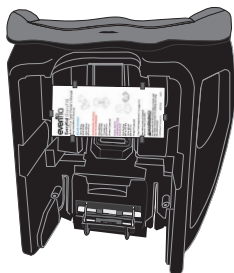

Using Your Booster Seat in Backless Booster Mode

Using the Shoulder Belt Clip

If the shoulder belt does not cross midway between child's shoulder and neck, then the shoulder belt clip must be used.

1. Attach shoulder belt clip as shown.

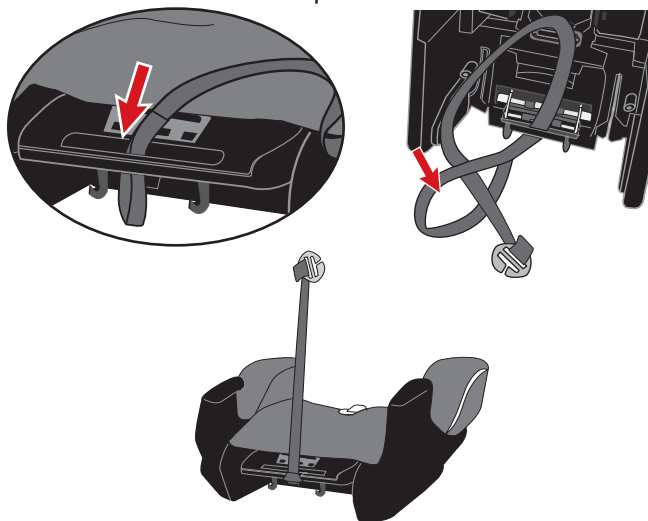

2. Place booster on vehicle seat.

Attach the shoulder belt clip **(A)** to the vehicle shoulder belt **(B)**.

3. Adjust shoulder belt clip.

Pull the adjustment strap **(C)** until the belt clip **(A)** is even with the child's shoulder, and the vehicle shoulder belt **(B)** lays across the child's chest midway between shoulder and neck.



Reverse steps above to remove shoulder belt clip before converting to high-back booster mode (pg. 63) or harness mode (pg. 57).

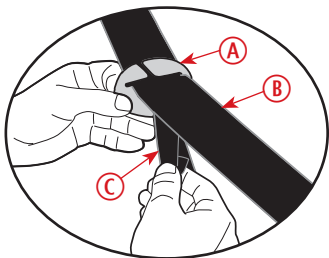

Backless Booster Installation Checklist

- 1. Remove the backrest from the booster seat.**
 - ✓ See "Converting Seat into Backless Booster" (pg. 60).
- 2. Move user guide to storage slots underneath base.**
- 3. Place the booster seat on the vehicle seat.**
 - ✓ Make sure the booster seat is in the upright position.
- 4. Set the child in the booster seat.**
 - ✓ Make sure the child's back is flat against the vehicle seat and the child's bottom is flat against the booster seat.
- 5. Secure the child and booster seat to the vehicle seat.**
 - ✓ Stretch the lap/shoulder belt across the child and fasten the buckle.
- 6. Use the shoulder belt clip, if necessary.**
 - ✓ If the vehicle's shoulder belt naturally crosses the child's shoulder, you do not need to use the shoulder belt clip. If the shoulder belt does not properly lay midway between the child's shoulder and neck, attach and adjust the belt clip. See "Using the Shoulder Belt Clip" (pg. 61).
- 7. Check your work.**
 - ✓ Make sure the lap belt is stretched low and snug across the child's hips, beneath the belt guides, and fastened into the buckle. The shoulder belt must cross the child midway between his/her shoulder and neck.

! WARNING! DEATH or SERIOUS INJURY can occur.

The shoulder belt **MUST NOT** cross the child's neck or fall off the child's shoulder. If you cannot adjust the shoulder belt to properly lay midway between the child's shoulder and neck, try another seating location or do not use the booster seat.



IMPORTANT: Always secure the booster seat with the vehicle seat belts when not occupied. An unsecured booster seat can fly into and injure other occupants in the event of a crash.

Reattaching the Booster Back

1. Replace crotch buckle if seat will be used in harness mode. See page 67.
2. Slide buckle tongues and chest clip up toward the headpad, and ensure the harness straps are straight and not twisted.

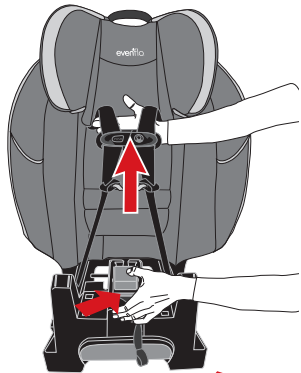

NOTE: Shorten harness adjust strap so that it is about 3" long and place it over harness release button. Tuck end of strap into slot above harness release button.

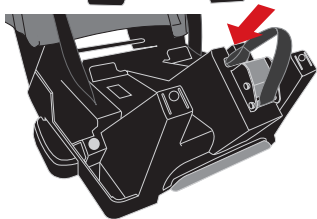

3. Grasp armrests firmly and slide booster base over back of seat.

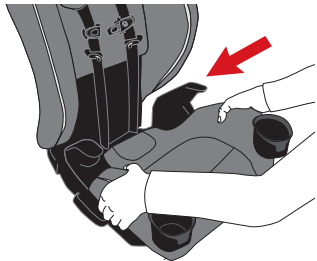

4. Press down firmly with hand over handle area. A click will indicate that the booster is attached to the back.

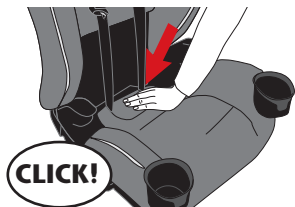

NOTE: Ensure that harness straps (A) are in the slots correctly before pushing base completely onto back.

5. Pull harness adjuster strap (B) through slot in the front of the seat pad. It may be necessary to lift the front of the pad.

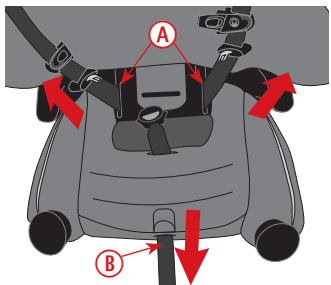

Reattaching Booster Back

To check installation of booster back:

Pull up on base to check that it is securely attached.

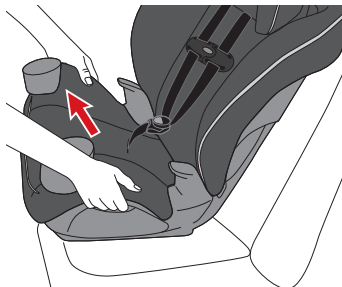

Ensure hooks are fully engaged over bar at back of seat.

IMPORTANT: You MUST ensure that the hooks are fully engaged around the bar before using seat.

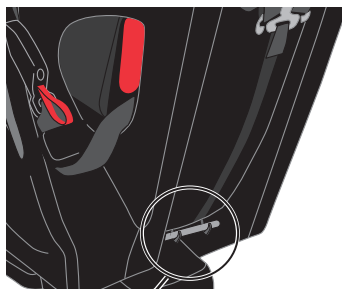

Harness straps (A), crotch buckle (B), and harness adjuster strap (C) are not twisted and are not trapped between Base and Seat Back.

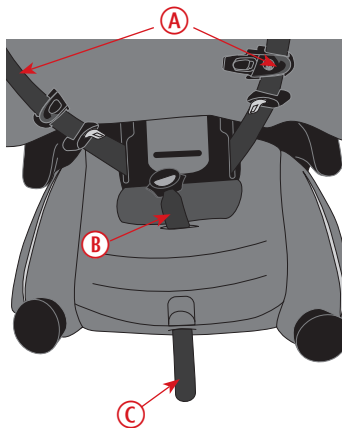

Adjusting the Headrest/Harness Position

To adjust, squeeze the headrest adjustment handle while sliding the headrest up or down to the desired position.

When the headrest is in one of the locking positions, the adjustment handle will lock into its original position. Pull up and down on the headrest to ensure it is locked into position.

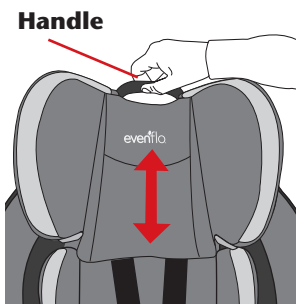

NOTE: You may need to loosen the harness straps (pg. 56) to adjust the headrest.

Rear-facing: Start with the headrest in its lowest position. Adjust headrest so the harness straps are **at or just below** the child's shoulders.

Forward-facing: Start with the headrest in its highest position. Adjust headrest so the harness straps are **at or just above** the child's shoulders.

NOTE: If using the lower Headrest/Harness positions, make sure to tuck the excess Headrest Flap up behind the Headrest Pad.

The Headrest Flap is designed with two fold lines to allow for partial (A) or full storage (B) behind the Headrest Pad.

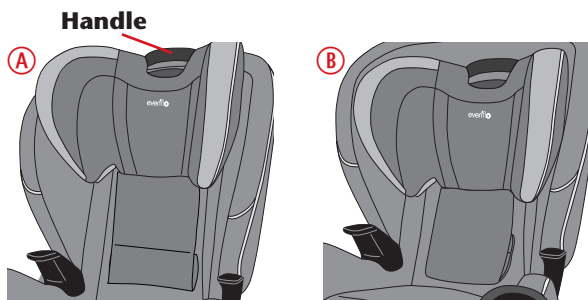

Reclining Child Restraint

To raise or lower the recline, pull the recline handle on the front edge of the seat and push or pull seat into the desired recline position as indicated below:



- **Rear-Facing:** The seat is in one of the three rear-facing recline positions, so that the level line is parallel to the ground.

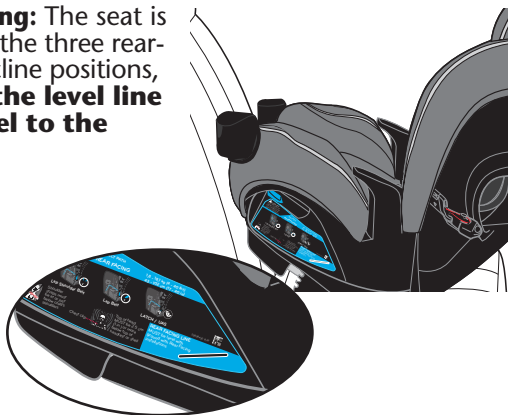

- **Forward-Facing:** The seat is in the fully upright position as shown.



Adjusting the Crotch Buckle Position

To reposition the crotch buckle, first remove the seat back from the base (pg. 60).

Looking under the base, turn the crotch buckle harness anchor sideways and push it through the slot in the bottom of the seat shell.

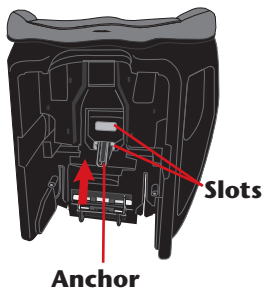

Reposition the crotch buckle into the other slot. Make certain the crotch buckle anchor is properly seated against the base.

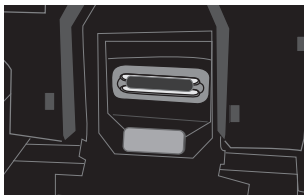

Bottom view

Crotch Buckle Positions:

Inner Slot: The crotch buckle must be in inner slot for rear-facing installations, and for forward-facing installations with children who weigh less than 30 lbs (13.6 kg).

Outer Slot: The crotch buckle must be in outer slot for forward-facing installations with children who weigh 30 lbs (13.6 kg) or more.

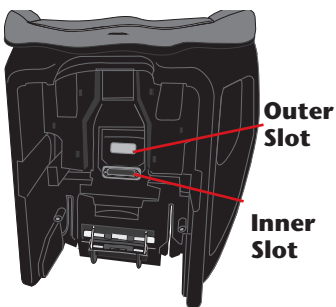

Securing the Child in the Child Restraint

Place baby in the child restraint. **The baby's back and bottom should be flat against the restraint.** If there is a gap, the baby will not be comfortable.



1. Push the harness release button on the front of the seat. At the same time, pull on the harness straps.

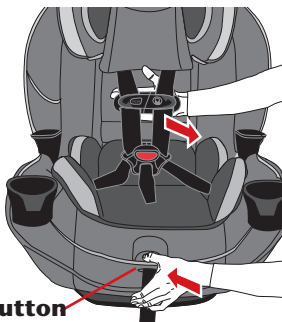

Button

2. Unbuckle harness and unfasten chest clip. Store buckle tongues in Buckle Tongue Pockets if available.

Place child in child restraint. Check crotch buckle position. See pg. 67 for correct crotch buckle positions and to change positions.



Bring each harness strap over the child's shoulders.

3. In **Rear-facing** mode, start with the headrest in its lowest position. Adjust headrest so harness straps are **at or just below** the child's shoulders.

In **Forward-facing**

mode, start with headrest in its highest position. Adjust headrest so harness straps are **at or just above** the child's shoulders.



NOTE: The child's head should be centered within the headrest.

Securing the Child in the Child Restraint

4. Insert both buckle tongues into the buckle. Pull up on the harness strap to check that the buckle tongues are fastened and to remove any slack from the webbing around the child's legs.

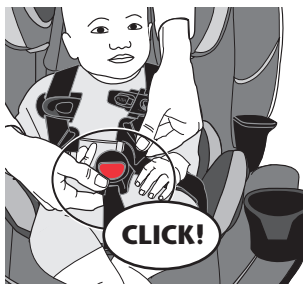

5. Snap the two halves of the chest clip together, as shown, and slide to armpit level.

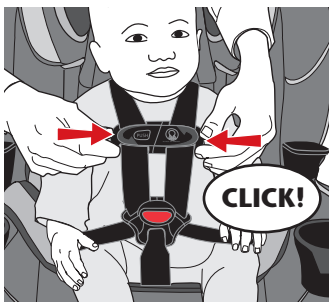

6. Hold the chest clip while pulling the harness adjustment strap so that the chest clip does not ride up into the child's neck.

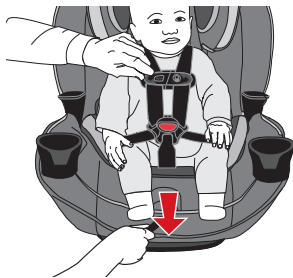

The harness straps must be snug against the child. A snug strap should not allow any slack. It lies in a relatively straight line without sagging. It does not press on the child's flesh or push the child's body into an unnatural position.

7. Check the harness straps near the shoulders for slack. You should **NOT** be able to pinch the harness (see illustration). Adjust as needed.

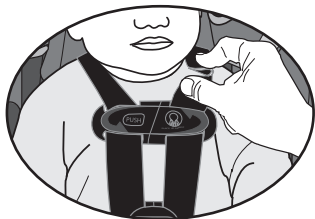

Removing the Child from the Child Restraint

1. Loosen the harness strap by pressing the harness release button located on the front of the seat.

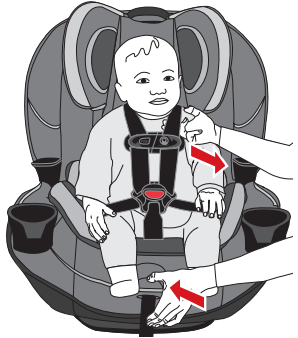

2. While pressing the button, pull out on the harness straps. To unfasten the chest clip, push the release button and pull apart.

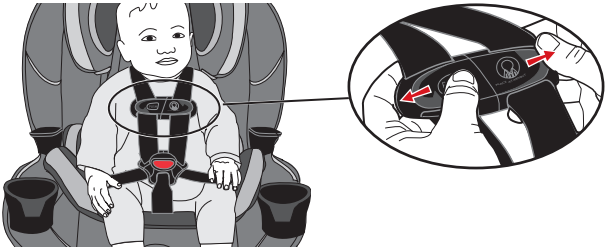

3. Press the red buckle release, and remove the buckle tongues.

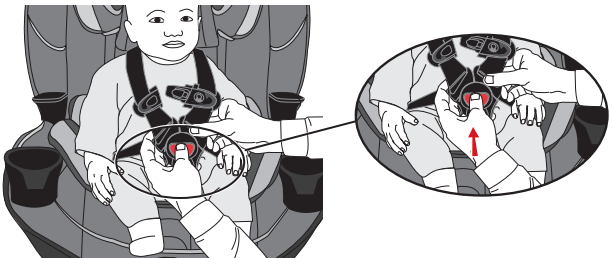



Removing the Tether Strap

⚠ WARNING! DEATH or SERIOUS INJURY can occur.

- To avoid a strangulation hazard, you **MUST** tightly roll or fold excess tether strap and secure with the strap/ rubber band.
- Attach the tether hook to one of the two storage clips on the seat back when not in use (**rear-facing mode only**). This will keep an unused tether or tether hook from hitting someone during a crash.

1. Press the adjuster release button to loosen tether strap.



TIP!

Push the child restraint into the vehicle seat back while loosening the adjuster

2. Press the tab and twist, then remove the hook from the anchor.

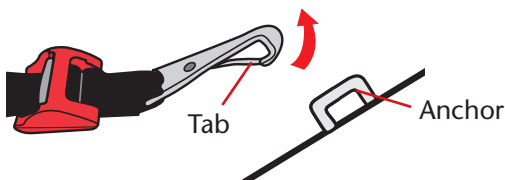

3. When the tether strap is not in use you **MUST** attach the hook to the back of the child restraint. **A loose tether strap and hook may injure your child.**

To remove, see Step 2, above.

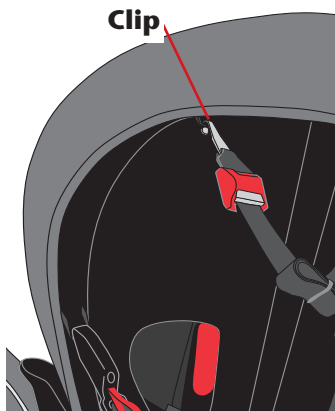

General

Installing Child Restraint Rear-facing in Aircraft



The Federal Aviation Administration (FAA) recommends that you secure your child for air travel in an appropriate child restraint based on your child's weight and size. Turbulence can happen with little or no warning. When turbulence occurs, **the safest place for your child is in a properly installed child restraint, not in an adult's lap or on the aircraft seat with its seat belt.** Keeping your child in a child restraint during the flight will help ensure your family arrives safely at your destination.

The FAA recommends that a child weighing:

- more than 18 kg (40 lbs) use an aircraft seat belt;
- less than 9 kg (20 lbs) use a rear-facing child restraint; and
- from 9 - 18 kg (20 - 40 lbs) use a forward-facing child restraint. **This restraint CANNOT be used in booster mode in aircraft.**

Please note that these FAA recommendations may vary from those applicable to the use of your child restraint in a motor vehicle.

IMPORTANT: Before installing the child restraint, **make sure the aircraft seat is in a fully upright position.**

1. Unbuckle the aircraft seat belts and lay over the armrests, as shown. Place the child restraint on the aircraft seat **rear-facing**. Adjust the restraint **so the level line is parallel to the ground** (pg. 33).

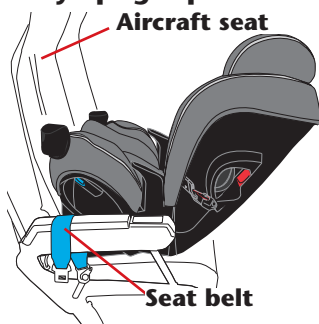

2. Pull the seat pad off the front of the child restraint. Route the aircraft seat belt through the rear-facing belt path opening on one side and continue through the belt path opening on the opposite side of the child restraint, as shown above.

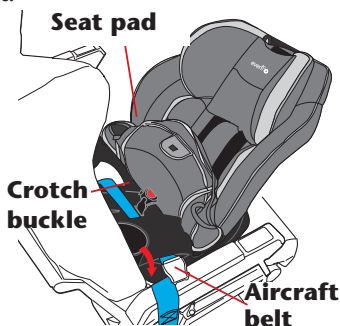

IMPORTANT: Make sure the aircraft seat belt is **in front of the crotch buckle**, as shown.

DO NOT use the lock-off when installing in aircraft.



Installing Child Restraint Rear-facing in Aircraft

3. Fasten the aircraft seat belt.

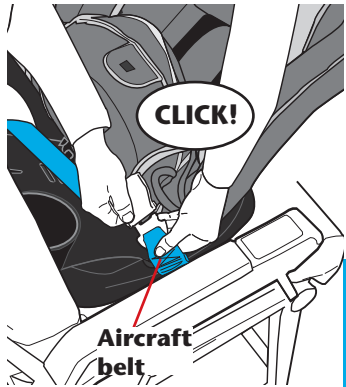

4. The aircraft seat belt must be as tight as possible. Route the excess seat belt strap back through the rear-facing belt path opening, as shown above. Reconnect the seat pad to the front of the child restraint. Using your full weight, push the child restraint firmly onto the aircraft seat while pulling on the excess seat belt strap to tighten.

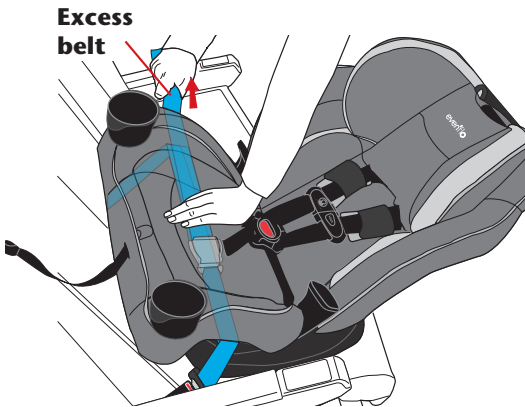

Check your work. Try to move the child restraint in all directions. If you can move the restraint more than 2.5 cm (1 in.) side to side or front to back at the rear-facing belt path, the aircraft seat belt is not tight enough, and you **MUST** install again until the seat belt is tight.

Installing Child Restraint Forward-facing in Aircraft



IMPORTANT: Before installing the child restraint, **make sure the aircraft seat is in a fully upright position.**



1. Adjust the child restraint to the fully upright position, then place it on the aircraft seat **forward-facing.**

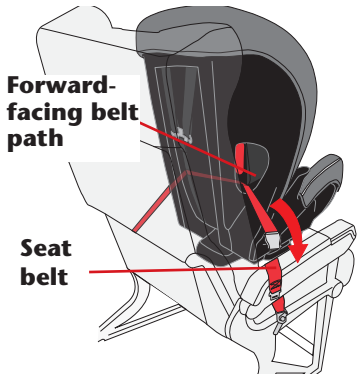

2. Route the aircraft seat belt through the forward-facing belt path opening in the back of the child restraint and continue through the belt path opening on the opposite side of the child restraint.

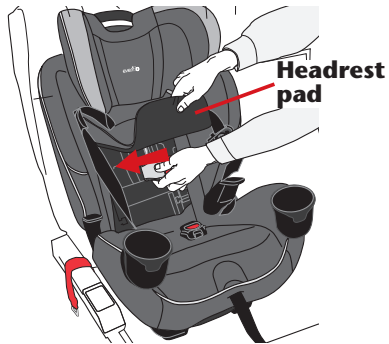

NOTE: Lift the restraint's headrest pad away for easier access.

DO NOT use the lock-off when installing in aircraft.





Installing Child Restraint Forward-facing in Aircraft

3. Fasten the aircraft seat belt.
4. The aircraft seat belt must be as tight as possible. Route the excess aircraft seat belt strap back through the forward-facing belt path opening, as shown. Using your full weight, push the child restraint firmly onto the aircraft seat while pulling on the excess seat belt strap to tighten.



NOTE: Because of the fixed length of aircraft seat belts, the belt buckle could be behind the child's back after tightening the belt. For your child's comfort, Evenflo recommends cushioning the child's back by placing a small pillow or folded-up blanket, or a folded-up jacket, over the belt buckle.

Check your work. Reconnect the seat pad to the child restraint. Try to move the child restraint in all directions. If you can move the restraint more than 2.5 cm (1 in.) side to side or front to back at the forward-facing belt path, the aircraft seat belt is not tight enough, and you **MUST** install again until the seat belt is tight.

Removing the Seat Cover

1. Push the harness release button on the front of the seat. At the same time, pull on the harness straps.

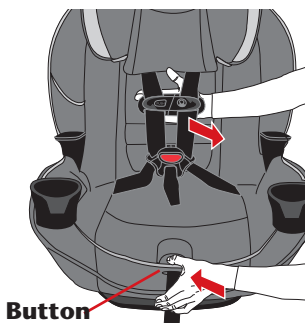

2. Raise headrest and remove elastic straps from around headrest adjustment handle.

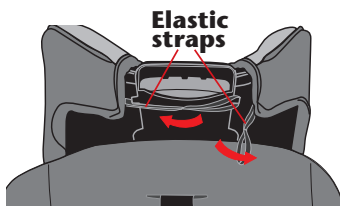

3. Slide headrest pad over headrest and remove the elastic straps from vehicle belt guides.

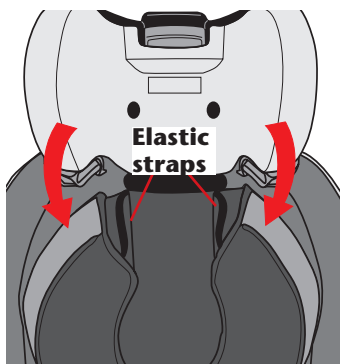

4. Pull the harness strap out of the opening in the headrest pad, and remove headrest pad from seat.

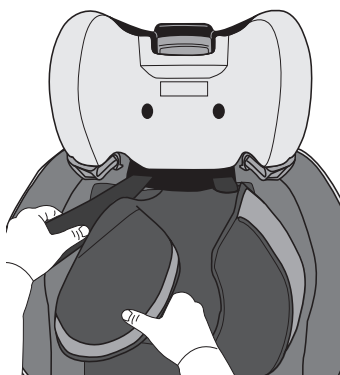

Removing the Seat Cover

5. From the back of the seat, loosen the top of the back pad, and pull the tether strap through the slot in the cover.

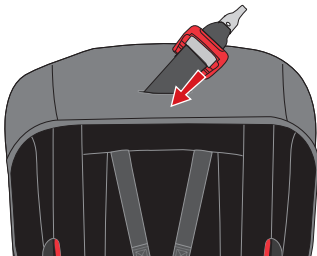

6. On either side of the back pad, pull the corners of the cover off the seat shell.

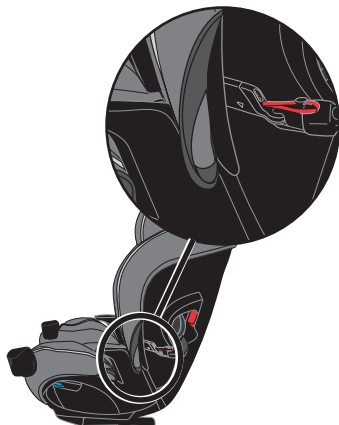

7. Disconnect the hook-and-loop connectors in the lower part of back pad, and lift cover off of seat.

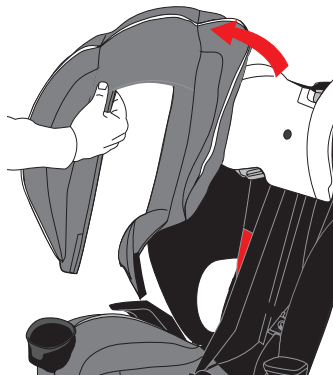

Removing the Seat Cover

8. Disconnect snaps on both sides of the front of the seat, and lift up.

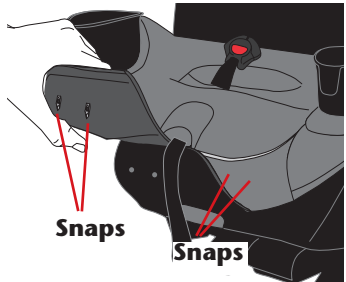

9. Disconnect elastic straps at back and remove pockets from tabs on either side of seat pad.

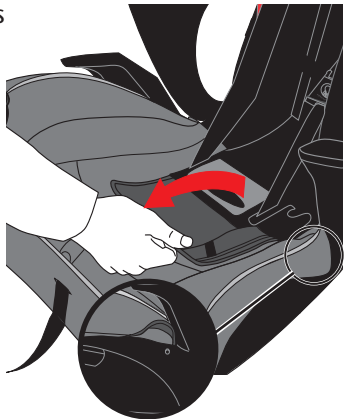

10. Push buckle through slot in seat. Remove seat pad from seat.

NOTE: It is not necessary to remove the cup holders in order to remove the seat pad.

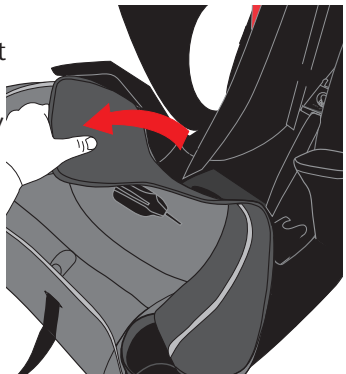

Reattaching the Seat Cover

1. Pull seat pad over seat base and reconnect snaps on front of seat at both sides. Pull harness adjust strap through slot at front of seat pad, and pull crotch buckle through slot in seat.

NOTE: It is not necessary to remove the cup holders in order to replace the seat pad.

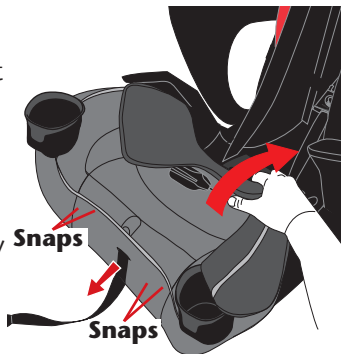

2. Reconnect elastic straps at back of seat and insert tabs at sides of seat into pockets on either side of seat pad.



3. Place the back pad around the upper seat shell. Reconnect the hook-and-loop fasteners at lower opening of back pad.

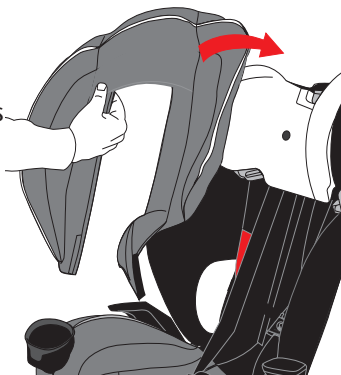

Reattaching the Seat Cover

4. Insert the corners into the pockets on either side of back pad.



5. Replace headrest pad. Pull tether strap through slot in back of back pad.

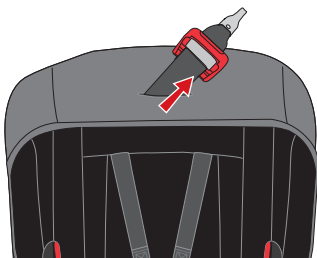

6. Replace elastic straps around shoulder belt guides. Pull harness straps through opening in headrest pad.

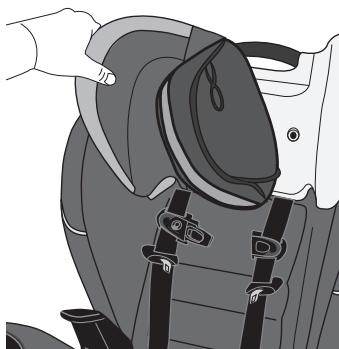

7. Attach elastic straps around headrest adjustment handle.

NOTE: Elastic straps are routed under tab and attached to tab at opposite side.

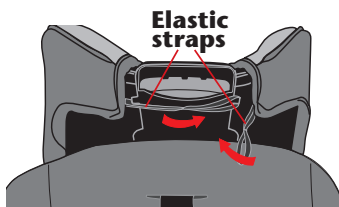

Care and Cleaning

- **DO NOT** lubricate or immerse in water the LATCH connectors, the buckle, or any other part of this child restraint, unless rinsing is permitted, as stated on the back of the buckle for your restraint.
- Plastic and metal parts may be wiped clean with mild soap and water and dried with a soft cloth. Do not use abrasive cleaners or solvents.
- Take care not to damage any labels.
- The harness can be wiped clean with mild soap and water. Allow harness to air dry.
- Machine wash soft goods separately in cold water, delicate cycle, NO CHLORINE BLEACH. Tumble dry 10 - 15 minutes on low heat. Remove immediately. Soft goods include seat pad, headrest pad, back pad, head pillow, body pillow, harness cover, and crotch buckle cover.*
- **NEVER** use child restraint without the seat pad.
- To protect the child restraint from damage caused by weather, rodents, and other elements common to garages, the outdoors, and other storage locations, remove the seat pad and thoroughly clean the restraint and pad prior to storage. Take care to clean in the areas where crumbs and other debris tend to accumulate.

TIP!

To help protect the vehicle upholstery, place a towel beneath and behind the child restraint.

Recording Model Information

For future reference, record the model number of your child restraint **AND** the date of manufacture below.

Model Number: _____

Date of Manufacture: _____

Manufactured in / Fabriqué en
(year-month-day)/(année-mois-jour)

Name / Nom

Model / Modèle

Made in / Fabriqué en

Expires on/Expire le

Storing Your Instructions

After reading and following these instructions, store manual as shown in either side of the seat (for high-back mode) or in the slots on the base (for backless mode).

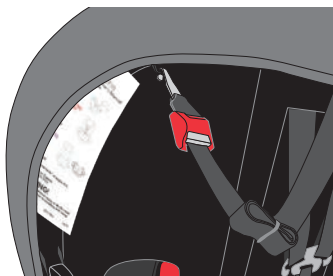

High-Back Mode

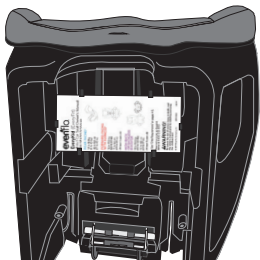

Backless Mode

Proper Disposal

When this child restraint reaches the expiration date found on the date of manufacture label, Evenflo encourages you to dispose of it properly. Most components of this child restraint are recyclable.

1. Remove all fabric and padding.
2. Remove all screws and disassemble the restraint.
3. Recycle all fabric, padding, plastic, foam and metal parts, if accepted by your local recycling center. Responsibly discard the rest.

If your local recycling center won't accept the padding, you may dispose of it in the landfill.

To prevent injury due to hidden damage, lost instructions, outdated technology, etc., **discontinue use of this restraint after the expiration date on the label or if it has been involved in a crash.**

Replacement Parts

To order replacement parts you can order online at www.evenflo.com or contact Evenflo. When you contact us, please have the product model number and date of manufacture (found on the back of the child restraint). Not available on all models. Styles may vary.

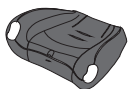

Seat Pad

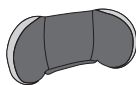

Head Pillow



Headrest Pad



Back Pad

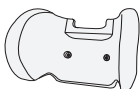

EPS Head Foam



Body Pillow



Snack Tray



Harness Covers



Cup Holder



Tether Extender



**Quick Connector™
with LATCH/UAS Guide
or**



EasyClick™

or



SecureRight™.



Crotch Buckle



Crotch Buckle Cover

Limited Warranty

For a period of 90 days from the original purchase of this Product, Evenflo warrants to the original end user ("Purchaser") this Product (including any accessories) against defects in material or workmanship. Evenflo's sole obligation under this express limited warranty shall be, at Evenflo's option, to repair or replace any Product that is determined to be defective by Evenflo and determined to be covered by this warranty.

Repair or replacement as provided under this warranty is the exclusive remedy of the Purchaser. Proof of purchase in the form of a receipted invoice or bill of sale evidencing that the Product is within the warranty period must be presented to obtain warranty service. This express limited warranty is extended by Evenflo ONLY to the original Purchaser of the Product and is not assignable or transferable to subsequent purchasers or end users of the Product. For warranty service, contact Evenflo's ParentLink Consumer Resource Center at www.evenflo.com.

EXCEPT TO THE EXTENT PROHIBITED BY APPLICABLE LAW, ANY IMPLIED WARRANTY OF MERCHANTABILITY OR FITNESS FOR A PARTICULAR PURPOSE ON THIS PRODUCT IS HEREBY DISCLAIMED. EVENFLO SHALL NOT BE LIABLE FOR ANY INCIDENTAL, CONSEQUENTIAL, SPECIAL OR PUNITIVE DAMAGES OF ANY KIND FOR BREACH OF THE EXPRESS LIMITED WARRANTY ON THIS PRODUCT, OR ANY WARRANTY IMPLIED BY OPERATION OF LAW. OTHER THAN THE EXPRESS LIMITED WARRANTY SET FORTH ABOVE, THERE ARE NO OTHER WARRANTIES THAT ACCOMPANY THIS PRODUCT AND ANY ORAL, WRITTEN OR ANY OTHER EXPRESS REPRESENTATION OF ANY KIND IS HEREBY DISCLAIMED.

ParentLink®

answers. advice. affirmation.™

USA: 1-800-233-5921, 8 AM - 5 PM E.T.

Canada: 1-937-773-3971

México: 01-800-706-12-00